

European Technical Assessment

ETA 18/0343
Version 01
Date of issue: 2018-06-12



UBAtc Assessment Operator:
Belgian Construction Certification Association
Rue d'Arlon 53 - 1040 Brussels
www.bcca.be - info@bcca.be



Technical Assessment Body issuing the European Technical Assessment: UBAtc.
UBAtc has been designated according to Article 29 of Regulation (EU) No 305/2011
and is member of EOTA (European Organisation for Technical Assessment)

Trade name of the construction product:

GEOTEC® S

Product family to which the construction product belongs:

35 - Fire Protective board

Manufacturer:

GEOSTAFF
19 Rue Fulgence Bienvenue
92230 Gennevilliers
France

Manufacturing plant(s):

01

Website:

www.geostaff.fr

This European Technical Assessment is issued in accordance with Regulation (EU) No 305/2011, on the basis of:

European Assessment Document (EAD):
EAD 350142-00-1106 (September 2017)

This European Technical Assessment contains:

51 pages, including 2 annexes, which form an integral part of the document.



**European Organisation
for Technical Assessment**

Legal bases and general conditions

- 1 This European Technical Assessment is issued by UBAtc (Union belge pour l'Agrément technique de la construction, i.e. Belgian Union for technical Approval in construction), in accordance with:
 - Regulation (EU) No 305/2011¹ of the European Parliament and of the Council of 9 March 2011 laying down harmonised conditions for the marketing of construction products and repealing Council Directive 89/106/EEC
 - Commission Implementing Regulation (EU) No 1062/2013² of 30 October 2013 on the format of the European Technical Assessment for construction products
 - European Assessment Document (EAD) : EAD 350142-00-1106
- 2 Under the provisions of Regulation (EU) No 305/2011, UBAtc is not authorized to check whether the provisions of this European Technical Assessment are met once the ETA has been issued.
- 3 The responsibility for the conformity of the performances of the products with this European Technical Assessment and the suitability of the products for the intended use remains with the holder of the European Technical Assessment.
- 4 Depending on the applicable Assessment and verification of constancy of performance (AVCP) system, (a) notified body(ies) may carry out third-party tasks in the process of assessment and verification of constancy of performance under this Regulation once the European Technical Assessment has been issued.
- 5 This European Technical Assessment allows the manufacturer of the construction product covered by this ETA to draw up a declaration of performance for the construction product.
- 6 CE marking should be affixed to all construction products for which the manufacturer has drawn up a declaration of performance.
- 7 This European Technical Assessment is not to be transferred to other manufacturers, agents of manufacturers, or manufacturing plants other than those indicated on page 1 of this European Technical Assessment.
- 8 The European Technical Assessment holder confirms to guarantee that the product(-s) to which this assessment relates, is/are produced and marketed in accordance with and comply with all applicable legal and regulatory provisions, including, without limitation, national and European legislation on the safety of products and services. The ETA-holder shall notify the UBAtc immediately in writing of any circumstance affecting the aforementioned guarantee. This assessment is issued under the condition that the aforementioned guarantee by the ETA-holder will be continuously observed.
- 9 According to Article 11(6) of Regulation (EU) No 305/2011, when making a construction product available on the market, the manufacturer shall ensure that the product is accompanied by instructions and safety information in a language determined by the Member State concerned which can be easily understood by users. These instructions and safety information should fully correspond with the technical information about the product and its intended use, which the manufacturer has submitted to the responsible Technical Assessment Body for the issuing of the European Technical Assessment.
- 10 Pursuant to Article 11(3) of Regulation (EU) No 305/2011, manufacturers shall adequately take into account changes in the product-type and in the applicable harmonised technical specifications. Therefore, when the contents of the issued European Technical Assessment do not any longer correspond to the product-type, the manufacturer should refrain from using this European Technical Assessment as the basis for their declaration of performance.
- 11 All rights of exploitation in any form and by any means of this European Technical Assessment is reserved for UBAtc and the ETA-holder, subject to the provisions of the applicable UBAtc regulations.
- 12 Reproduction of this European Technical Assessment including transmission by electronic means shall be in full. However, partial reproduction can be made with the written consent of UBAtc. In this case partial reproduction has to be designated as such. Texts and drawings of advertising brochures shall not contradict or misuse the European Technical Assessment.
- 13 Subject to the application introduced, this European Technical Assessment is issued in English and may be issued by the UBAtc in its official languages. The translations correspond fully to the English reference version circulated in EOTA.
- 14 This European Technical Assessment was first issued by UBAtc on 12 June 2018.

¹ OJEU, L 88 of 2011/04/04

² OJEU, L 289 of 2013/10/31

Technical Provisions

1 Technical description of the product

1.1 General

GEOTEC® S is a fire protective plasterboard, composed of plaster, mineral fibres and damp-proof if necessary. The product is whitish in colour. The upper surface is smooth and the reverse face is rough.

The GEOTEC® S boards may have rabbets.

The Fire Protective Boards are manufactured by GEOSTAFF at production plant 01 (known at UBAtc).

1.2 Dimensions and density

Dimensions and density of the boards are given in Table 1.

Table 1 - Dimensions and density GEOTEC® S

Density (dry-80°C): 720 kg/m ³ ± 15%		
Density (23°C, 50%RH): 750 kg/m ³ ± 15%		
Thickness (mm)	Length x width (mm)	Tolerances on length and width (mm)
30 ± 2	From 1000 x 200 up to 1000 x 1200	+5/-5
45 ± 2	From 1000 x 200 up to 1000 x 1200	+5/-5
(*) width increases in steps of 50 mm		

On special request other length and width dimensions may be available, respecting the tolerances as specified in Table 1.

1.3 Ancillary products

Ancillary products referred to in this ETA, as a part of installation provisions or in the framework of determining performances (e.g. fire resistance), are not covered by this ETA and may not be CE-marked on the basis of it.

2 Specification of the intended use(s) in accordance with the applicable EAD

2.1 Intended uses

This ETA covers fire protective boards intended for internal use only, excluding high humidity environments (type Z₂, see clause 1.2.3 in EAD 350142-00-1106).

GEOTEC® S is intended to protect elements or to be used in assemblies as specified in Table 2.

Table 2 shows the possible intended uses of the boards. Not all of these have been assessed in the framework of this ETA with regard to fire resistance performance. Annex 2 shows a list of the uses for which fire resistance assessment was carried out. This ETA covers assemblies installed in accordance with the provisions given in Annex 2.

With regard to fire resistance performance, the other intended uses may be supported by other means at national level (as specified in the note in paragraph 3.2.2 of this ETA).

Table 2 - Intended use

Protection of	EAD 350142-00-1106 reference
Horizontal membrane protection incl. suspended ceilings acc. to EN 13964	Type 1
Vertical membrane protection	Type 2
Load-bearing concrete elements	Type 3
Load-bearing steel elements	Type 4
Load-bearing flat concrete profiled sheet composite elements	Type 5
Load-bearing concrete filled hollow steel columns	Type 6
Load-bearing timber elements	Type 7
Fire separating assemblies with no load-bearing requirements	Type 8
Technical services assemblies in buildings	Type 9
Fire protective uses not covered by types 1-9	Type 10

The provisions made in this European Technical Assessment are based on an assumed intended working life of 10 years, provided that the assembled product is subject to appropriate use and maintenance, in accordance with this ETA.

Indications given regarding the working life cannot be interpreted as a guarantee given by the producer or the UBAtc, but are to be regarded only as a means for choosing the appropriate product(s) in relation to the expected economically reasonable working life of the construction works.

2.2 Assumptions under which the fitness of the product(s) for the intended use was favourably assessed

2.2.1 Manufacturing directives

The European technical assessment is issued for the product on the basis of agreed data/information, deposited with the approved body, which identifies the product that has been assessed and judged. Changes to the product or production process, which could result in this deposited data/information being incorrect, should be notified to the approved body before the changes are introduced. The approved body will decide whether or not such changes affect the ETA.

The raw materials are dosed and mixed in water before casting in suitable moulds. After a partial drying, the products are removed from the moulds and dried in the oven. Each board is marked in accordance with paragraph 6 of this ETA. Boards are examined for visual defects and non-compliant boards are rejected.

2.2.2 Installation

2.2.2.1 Supporting structure

The distance between supports shall be in accordance with the information provided in the assemblies described in annex 2 of this ETA.

2.2.2.2 Cutting and machining

The GEOTEC® S boards are manufactured in standard dimensions (cf. Table 1 of this ETA). If needed, the fire protective boards may be cut using a handsaw or electric equipment. The latter saw shall operate at a low speed

A safety data sheet is available from the manufacturer upon request.

2.2.2.3 Joints

The fire protective boards shall be butt jointed.

The boards can have square or rabbeted edges. The type of edge shall be in accordance with the assemblies described in annex 2.

The use and type of joint filler shall be in accordance with the assemblies described in annex 2.

2.2.2.4 Assembly

The boards shall be applied as specified in the assemblies in annex 2.

2.3 Recommendations

2.3.1 Recommendations on packaging, transport and storage

During transport and storage, the boards shall be stacked on a flat underground and protected against rain. Storage shall take place on pallets, in a sheltered and well-ventilated space.

2.3.2 Recommendations on use, maintenance and repair

Future modifications to the building should not adversely affect the fire protective properties of the system in which the boards are used. Care should be taken to prevent any reduction of fire performance as a result of increased applied load to protected elements of the works (e.g. beams, columns, ceilings, floors, or walls).

The assessment of the fitness for use is based on the assumption that damaged boards, for example due to accidental impact, are replaced. It is further assumed that replacement of components during maintenance/repair will be undertaken using materials specified by the ETA.

3 Performance of the product and references to the methods used for its assessment

3.1 Mechanical resistance and stability (BWR1)

This basic requirement for construction works is not relevant for GEOTEC® S boards according to EAD 350142-00-1106.

3.2 Safety in case of fire (BWR2)

3.2.1 Reaction to fire

The GEOTEC® S boards have a reaction to fire classification A1 according to EN 13501-1:2007+A1:2009.

3.2.2 Resistance to fire

Assemblies incorporating GEOTEC® S boards have a resistance to fire when tested according to EN 1366-1, EN 1366-5 or EN 1366-8 and classified according to EN 13501-2, EN 13501-3 or EN 13501-4, (EAD 350142-00-1106, ER2) as presented in Annex 2.

The tested assemblies horizontal and vertical ducts (intended use type 9), have a fire resistance classification as shown in the tables below.

Table 3

Technical ducts not used in ventilation installations	
Horizontal and vertical ducts Internal duct dimensions from 50 mm by 50 mm up to 2500 mm wide by 2000 or 1500 mm high, depending on the assembly method Installation details see Annex 2 of the ETA Resistance to fire classifications in accordance to EN 13501-2	
Board thickness (mm)	Classification
30	EI 60 ve ho i ↔ o
45	EI 120 ve ho i ↔ o

Table 4

Ventilation ducts	
Horizontal and vertical ducts Internal duct dimensions up to 2500 mm wide by 1500 mm or 2000 mm high, depending on the assembly method Installation details see Annex 2 of the ETA Resistance to fire classifications in accordance to EN 13501-3	
Board thickness (mm)	Classification
30	EI 60 ve ho i ↔ o S
45	EI 120 ve ho i ↔ o S

Table 5

Smoke extraction ducts	
Horizontal and vertical ducts Internal duct dimensions up to 2500 mm wide by 1500 mm or 2000 mm high, depending on the assembly method Installation details see Annex 2 of the ETA Resistance to fire classifications in accordance to EN 13501-4	
Board thickness (mm)	Classification
30	EI 60 S ve ho - 1500 / + 500 Pa Multi
45	EI 120 S ve ho - 1500 / + 500 Pa Multi

NOTE: This ETA covers a limited number of assemblies subjected to fire resistance assessment. As time progresses, the performance declaration for fire resistance covered by CE-marking should gradually be enlarged by the ETA-holder and incorporated in this ETA by amendment or revision. In the meantime, and taking into account the transitional arrangements for test and classification standards and the corresponding national legislation, the ETA-holder should be permitted to maintain and be able to use - on a national basis - his portfolio of test data for this characteristic, based on relevant national standards, next to the performance declaration covered by the CE-marking based on this ETA.

3.3 Hygiene, health and the environment (BWR3)

3.3.1 Air and/or water permeability

No performance assessed.

3.3.2 Release of dangerous substances

No performance assessed.

3.4 Safety in use (BWR4)

3.4.1 Mechanical resistance and Stability

3.4.1.1 Flexural strength

In accordance with EN 12467, the boards have a modulus of rupture (MOR) of $\geq 1,3$ MPa.

The boards have sufficient strength to support their own mass. The boards are not intended to support additional loads.

3.4.1.2 Dimensional stability

The dimensional stability on width and length, and on thickness of the GEOTEC® S boards tested in accordance with EN 318 is given in the table below.

Table 6 - Dimensional stability of GEOTEC® S boards

Relative change in length or width		
Range	30 mm	45 mm
65% to 30%	0,1 (0,1/0,1)	0,2(0,2/0,1)
65% to 85%	0,0 (0,0/0,0)	0,0 (0,0/0,0)
Relative change in thickness		
Range	30 mm	45 mm
65% to 30%	-0,2(-0,1/-0,3)	-0,2(-0,2/-0,1)
65% to 85%	-0,2 (-0,1/-0,4)	0,0 (0,1/-0,1)

3.5 Protection against noise (BWR5)

3.5.1 Sound absorption

No performance assessed

3.5.2 Airborne sound insulation

Airborne sound insulation of 30 mm and 45 mm GEOTEC® S boards is tested according to the EN ISO 10140 series and assessed EN ISO 717-1.

Airborne sound insulation of GEOTEC® S boards is :

- For 30 mm boards : RW (C;Ctr) = 29 (-2;-2) dB
- For 45 mm boards : RW (C;Ctr) = 31 (-1;-2) dB

3.5.3 Impact sound insulation

No performance assessed

3.6 Energy and heat retention (BWR6)

3.6.1 Thermal insulation

The thermal conductivity is tested according to EN 12664:2002.

- For 30 mm boards : $\lambda = 0,106$ W/m.K
- For 45 mm boards : $\lambda = 0,123$ W/m.K

3.6.2 Water vapour transmission coefficient

No performance assessed

3.7 Aspects of durability, serviceability and identification

3.7.1 Durability and serviceability

Product performances confirm a working life of minimum 10 years of the GEOTEC® S boards for the intended use Z₂ (internal use).

3.7.2 Identification

3.7.2.1 Length, Width

The length of the GEOTEC® S boards is 1000 mm as presented in Table 1.

The width of the GEOTEC® S boards is between 200 mm and 1200 mm increasing in 50 mm steps, as presented in Table 1.

Other lengths and widths, not exceeding the above-mentioned maximum dimensions, may be available on special request.

3.7.2.2 Thickness

The thickness of the GEOTEC® S boards is 30 mm or 45 mm, as presented in Table 1.

3.7.2.3 Dimensional tolerances

The tolerances of the GEOTEC® S boards is ± 5 mm on length and on width. The tolerance on the thickness is ± 2 mm, as presented in Table 1.

3.7.2.4 Shape

The straightness of the edges and the squareness of the GEOTEC® S boards respect the level II criteria of clause 5.3.5 in EN 12467.

3.7.2.5 Apparent density

The apparent density of the boards is $750 \text{ kg/m}^3 \pm 15\%$.

4 AVCP system applied, with reference to its legal base

In accordance with Regulation (EU) N° 305/2011, Directive 89/106/EEC is repealed, but references to the repealed Directive shall be construed as references to the Regulation.

The system(s) of assessment and verification of constancy of performance (AVCP), specified in the Decision of the Commission 1999/454/EC of 1999/07/14³, are specified in the following Table 7.

Table 7 - System of AVCP applicable for GEOTEC® S boards

Product(s)	Intended use(s)	Level(s) or class(es)	AVCP system(s) ^(a)
Fire protective products	For fire compartmentation and/or fire protection or fire performance	Any	1

^(a) See Annex V to Regulation (EU) N° 305/2011

³ OJEU L178/52 of 1999/07/14

Table 8 - The system of AVCP applicable fire protective products with respect to reaction to fire

Product(s)	Intended use(s)	Level(s) or class(es) (reaction to fire)	AVCP system(s) ^(a)
Fire protective products	For uses subject to regulations on reaction to fire	(A1, A2, B, C)*	1
		(A1, A2, B, C)**, D, E, F	3
		(A1 to F)***, NPD***	4

^(a) System 1, 3 and 4 : See Regulation (EU) N° 305/2011, Annex V
* Products/materials for which a clearly identifiable stage in the production process results in an improvement of the reaction to fire classification (e.g. an addition of fire retardants or a limiting of organic material)
** Products/materials not covered by footnote (*)
*** Products/materials that do not require to be tested for reaction to fire (e.g. products/materials of class A1 according to Commission Decision 96/603/EC⁴, as amended)
**** 'No Performance Declared' in accordance with Regulation (EU) N° 305/2011, Article 6(f)

In addition, according to the Commission Decision 1999/454/EC¹, as amended, the system of assessment and verification of constancy of performance given in Table 8 apply to fire protective products with regard to reaction to fire.

For initial type testing of the product the task for the notified body is limited to the following characteristics:

- Reaction to fire
- Resistance to fire
- Mechanical resistance and stability
- Release of dangerous substances

For initial inspection of the factory and of FPC, and for continuous surveillance, judgment and assessment of the FPC, parameters related to the following characteristics are of interest to the notified body:

- Reaction to fire
- Mechanical resistance and stability

The system of Assessment and verification of constancy of performance is specified in the EC Decision 99/454/EC, as amended by EC Decision 2001/596/EC⁴, is system 1, 3 or 4, depending on the classes declared.

For Fire protective Products under systems 1 and 3, regarding the initial type testing of the product, the task for the notified laboratory is limited to the assessment of the Euroclass characteristics for reaction to fire, as indicated in the Commission Decision 94/611/EC⁵.

For Fire Protective Products under system 1, for initial inspection of the factory and of FPC, and for continuous surveillance, assessment and approval of the FPC, parameters related to the Euroclass characteristics for reaction to fire, as indicated in the Commission Decision 94/611/EC are of interest of the notified body.

5 Technical details necessary for the implementation of the AVCP system, as foreseen in EAD 350142-00-1106

5.1 Tasks for the ETA-holder

5.1.1 Factory production control (FPC)

The ETA-holder shall exercise permanent internal control of the production. All the elements, requirements and provisions adopted by the ETA-holder shall be documented in a systematic manner in the form of written policies and procedures. This factory production control system shall ensure that production is in conformity with this ETA.

The personnel involved in the production process shall be identified, sufficiently qualified and trained to operate and maintain the production equipment. Machinery equipment shall be regularly maintained and this shall be documented. All processes and procedures of production shall be recorded at regular intervals.

The ETA-holder shall maintain a traceable documentation of the production process from purchasing or delivery of raw or basic raw materials up to the storage and delivery of finished products.

The factory production control system for the product includes relevant design specifications, including adequate drawings and written instructions for:

- type and quality of all materials
- overall dimensions
- packaging and transport protection

The production control system shall specify how the control measures are carried out, and at which frequencies.

ETA-holders, which have an FPC system that complies with EN ISO 9001 and that addresses the requirements of this ETA, are recognised as satisfying the FPC requirements.

Products that do not comply with requirements as specified in the ETA shall be separated from the conforming products and marked as such. The ETA-holder shall register non-compliant production and action(-s) taken to prevent further non-conformities. External complaints shall also be documented, as well as actions taken.

When materials/products are delivered for incorporation into the production process, verification of conformity with specifications in the quality manual shall take place and recorded

If supplied materials/components are not manufactured and tested by the supplier in accordance with agreed methods, or where the ETA-holder purchases materials/components on the open market, then where appropriate, they shall be subject to suitable documented checks/tests by the ETA-holder before acceptance.

⁴ OJ L209 of 2001/08/02

⁵ OJ L241/25 of 1996/09/16

The characteristics of incoming material and components, for which the supplier demonstrates documented compliance with a product specification, for an intended use that is appropriate for its use as a raw material or component of the product, shall be considered satisfactory and need, except in justified doubt, no further checking, unless the control plan specifies differently.

5.1.2 Testing of samples taken at the factory

5.1.2.1 General

At least the following minimum information shall be recorded:

- date and time of manufacture
- type of product produced (boards)
- material specification (dimensions and thickness)
- all results of the verifications performed within the agreed upon control plan

5.1.2.2 Maintenance, checking and calibration of equipment

All testing equipment shall be maintained, calibrated and/or checked against equipment or test specimens traceable to relevant international or nationally recognised reference test specimens (standards). In case no such reference test specimens exist, the basis used for internal checks and calibration shall be documented.

The ETA-holder shall ensure that handling, preservation and storage of test equipment is such that performances are maintained

When production is intermittent, the ETA-holder shall ensure that any test equipment which may be affected by the interruption is suitably checked and/or calibrated before use. The calibration of all test equipment shall be repeated if any repair or failure occurs which could upset the calibration of the test equipment.

5.1.2.3 Testing as part of Factory Production Control

Table 9 specifies minimum requirements for testing as part of the Factory Production Control (FPC).

If constituent materials or components are supplied by other manufacturers to the ETA-holder, the supplier shall perform FPC on those constituent materials or components. If that is the case, those suppliers should submit the relevant records to the ETA-holder.

Table 9 - FPC test plan for GEOTEC® S boards

Property	Minimum frequency
Determination of organic content (reaction to fire)	1 per week ⁶
Determination of dimensional stability at high temperatures (fire resistance)	1 per week
Indirect test method (small oven test) ⁷	1 per year
Dimensional stability	1 per year
Identification	
Length, width	1 per day ⁸ , per dimension
Thickness	1 per day, per thickness
Apparent density	1 sample per n-boards
Flexural strength	1 sample per n-boards

5.2 Initial Type Testing

The assessment tests will have been conducted by the UBAtc or under its responsibility (which may include a proportion conducted by an independent laboratory or by the ETA-applicant, witnessed by the UBAtc). The UBAtc will have assessed the results of these tests in accordance with chapter 3 of this ETA, as part of the ETA issuing procedure.

The results of assessment testing shall be used by notified bodies (cf. Regulation (EU) 305/2011, Annex V, clause 1.6).

6 Other marking and/or information

Each board shall at least be marked with product name and a traceability code. Each package is marked with the product name, traceability code, thickness of the boards, and dimensions of the boards.

⁶ A week represents 5 production days.

⁷ Production shall be subjected to a small oven test (test performed on one thickness).

⁸ A day represents a 24h time period in which production is considered to be as usual for the production facility concerned.

UBAtc asbl is a non-profit organization according to Belgian law. It is a Technical Assessment Body notified by the Belgian notifying authority, the Federal Public Services Economy, SMEs, Self-Employed and Energy, on 17 July 2013 in the framework of Regulation (EU) No 305/2011 of the European Parliament and of the Council of 9 March 2011 laying down harmonised conditions for the marketing of construction products and repealing Council Directive 89/106/EEC and is member of the European Organisation for Technical Assessment, EOTA (www.eota.eu).

This European Technical Assessment has been issued by UBAtc asbl, in Sint-Stevens-Woluwe, on the basis of the technical work carried out by the Assessment Operator, BCCA.

On behalf of UBAtc asbl,

On behalf of the Assessment Operator, BCCA,
responsible for the technical content of the
ETA,



Peter Wouters,
director



Benny De Blaere,
director general

The most recent version of this European Technical Assessment may be consulted on the UBAtc website (www.ubatc.be).

Annex I : References

Reference number EAD 350142-00-1106 (edition 2017)

Document title Fire protective products – FIRE PROTECTIVE BOARD, SLAB AND MAT PRODUCTS AND KITS.

Reference number EN 13964:2004

Document title Suspended ceilings - Requirements and test methods.

Reference number EN 12467:2004

Document title Fibre-cement flat sheets - Product specification and test methods

Reference number EN 13501-1:2002

Document title Fire classification of construction products and building elements - Part 1: Classification using test data from reaction to fire tests

Reference number EN 13501-2:2003

Document title Fire classification of construction products and building elements - Part 2: Classification using data from fire resistance tests, excluding ventilation services

Reference number EN 13501-3:2006

Document title Fire classification of construction products and building elements - Part 3: Classification using data from fire resistance tests on products and elements used in building service installations: fire resisting ducts and fire dampers

Reference number EN 13501-4:2007

Document title Fire classification of construction products and building elements - Part 4: Classification using data from fire resistance tests on components of smoke control systems

Reference number EN 1366-1:1999

Document title Fire resistance tests for service installations - Part 1: Ducts

Reference number EN 1366-5:2010

Document title Fire resistance tests for service installations - Part 5: Service ducts and shafts

Reference number EN 1366-8:2004

Document title Fire resistance tests for service installations - Part 8: Smoke extraction ducts

Reference number EN 318:2002

Document title Wood based panels - Determination of dimensional changes associated with changes in relative humidity

Reference number EN ISO 10140-x:2010

Document title Acoustics - Laboratory measurement of sound insulation of building elements

Reference number EN ISO 717-1:1996

Document title *Acoustics - Rating of sound insulation in buildings and of building elements - Part 1: Airborne sound insulation*

Reference number EN 12664

Document title Thermal performance of building materials and products - Determination of thermal resistance by means of guarded hot plate and heat flow meter methods - Dry and moist products of medium and low thermal resistance

NOTE: The editions of reference documents given above are those, which have been adopted by the UBAtc for its specific use when establishing this ETA. When new editions become available, these supersede the editions mentioned only when confirmed by the UBAtc.

Annex II : Fire resistance performances and assembly methods for uses of boards covered by this ETA

Annex 2.0: Overview of fire resistance performances for GEOTEC® S assemblies

The fire protective assemblies in Table A.2.0.1 have been assessed within the framework of this ETA. Assemblies installed according to the provisions given in this annex are covered by this ETA.

Table A.2.0.1

Assembly assessed within the framework of this ETA	Classification according to EN 13501-2	Test standard	Intended use *	Installation details	Date of addition to this ETA
Horizontal and vertical protection of service ducts and shafts composed of GEOTEC® S 30 fire protective boards	EI 60 ve ho i ↔ o	EN 1366-5	Type 9	Annex 2.1	12/06/2018
Horizontal and vertical protection of service ducts and shafts composed of GEOTEC® S 45 fire protective boards	EI 120 ve ho i ↔ o	EN 1366-5	Type 9	Annex 2.1	12/06/2018
Assembly assessed within the framework of this ETA	Classification according to EN 13501-3	Test standard	Intended use *	Installation details	Date of addition to this ETA
Horizontal and vertical ventilation ducts composed of GEOTEC® S 30 fire protective boards	EI 60 ve ho i ↔ o S	EN 1366-1	Type 9	Annex 2.2	12/06/2018
Horizontal and vertical ventilation ducts composed of GEOTEC® S 45 fire protective boards	EI 120 ve ho i ↔ o S	EN 1366-1	Type 9	Annex 2.2	12/06/2018
Assembly assessed within the framework of this ETA	Classification according to EN 13501-4	Test standard	Intended use *	Installation details	Date of addition to this ETA
Horizontal and vertical smoke extraction ducts composed of GEOTEC® S 30 fire protective boards	EI 60 S ve ho -1500 / +500 Pa Multi	EN 1366-8	Type 9	Annex 2.3	12/06/2018
Horizontal and vertical smoke extraction ducts composed of GEOTEC® S 45 fire protective boards	EI 60 S ve ho -1500 / +500 Pa Multi	EN 1366-8	Type 9	Annex 2.3	12/06/2018

* Intended use type according to EAD 350142-00-1106

Annex 2.1: Specification of service ducts and shafts (intended use type 9), composed of GEOTEC® S fire protective boards,

A.2.1.1 Date of addition to this ETA

This annex was added to ETA 18/0343 on 2018-06-12. This assembly was not covered by this ETA prior to the addition of this annex.

A.2.1.2 Classification

The assembly described in this annex has been tested according to EN 1366-5 and classified (see table A.2.0.1) in accordance with EN 13501-2.

30 mm boards : **EI 60 ve ho i ↔ o**

45 mm boards : **EI 120 ve ho i ↔ o**

A.2.1.3 Installation requirements

Installation requirements in paragraph 2.2 of this ETA shall be taken into account.

A.2.1.4. Service ducts and shafts composed of GEOTEC® S boards assembled by caulking

A.2.1.4.1. General

The horizontal and vertical service ducts are composed of GEOTEC® S boards with a thickness of 30 mm or 45 mm. The internal dimensions of the ducts are between 50 mm by 50 mm and 2500 mm (wide) by 2000 mm (high)

A.2.1.4.2. Assembly

The ducts are composed of 1000 mm long sections, built up of 4 or more 30 mm or 45 mm GEOTEC® S boards. The boards are placed with the smooth face indifferently to the inside or outside of the duct and are mounted with or without a horizontal and vertical offset of the joints from one face to the other.

The 45 mm boards have 22 mm by 23 mm rabbets at the 4 sides. The 30 mm boards have 14 mm by 16 mm rabbets only on the long sides. These rabbets may ease the assembly.

Caulking of vegetable fibre + plaster (such as GEOPATRE N or similar) is applied on all joints (vertical and horizontal). The dimensions of this caulking is 50 mm by 10 mm on the horizontal or vertical joints and 20 mm by 20 mm in the corners.

A.2.1.4.3 Horizontal ducts

A.2.1.4.3.1. Supporting structure

The continuous self-supporting horizontal duct is composed of GEOTEC® S fire protective boards (see paragraph A.2.1.4.3.3 for details of the duct composition). The duct penetrates walls with a minimum thickness of 110 mm (30 mm boards) or 150 mm (45 mm boards) (or a partition with an equivalent resistance to fire performance characteristics – see paragraph A.2.1.4.3.4. for details of penetration). The duct is supported by steel suspension system at intervals of 1000 mm (30 mm or 45 mm boards), as illustrated by figures 2.1.4.3.1.a, 2.1.4.3.1.b and 2.1.4.3.1.c.

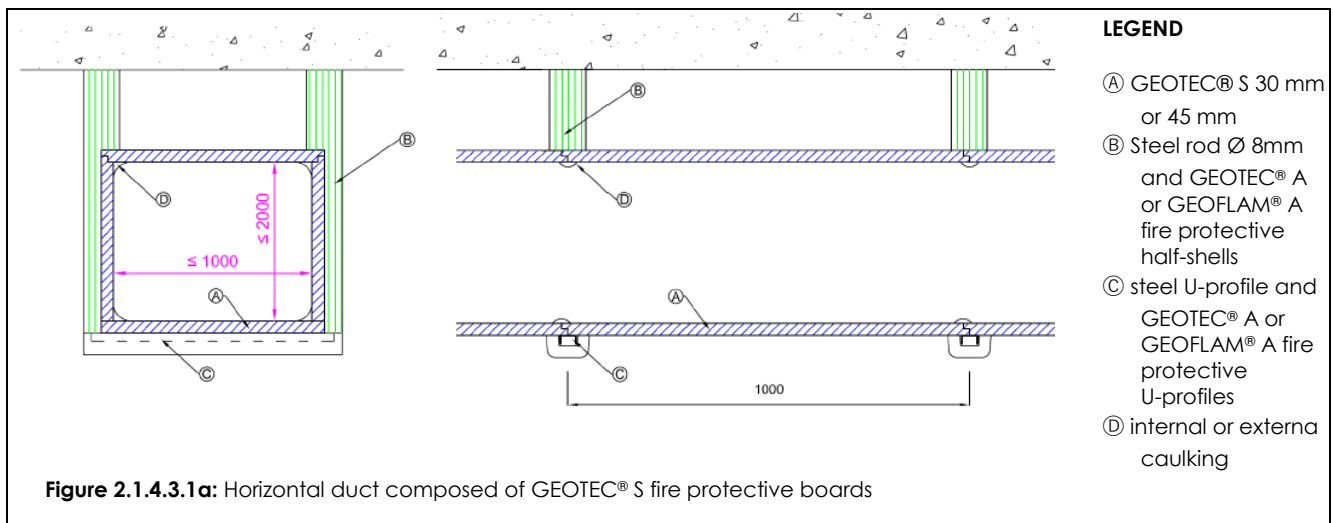

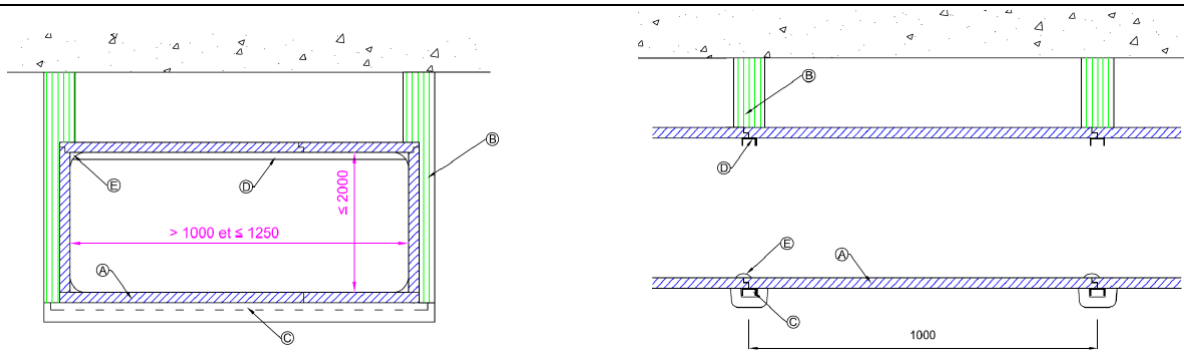

LEGEND

- (A) GEOTEC® S 30 mm or 45 mm
- (B) Steel rod Ø 8mm and GEOTEC® A or GEOFLAM® A fire protective half-shells
- (C) steel U-profile and GEOTEC® A or GEOFLAM® A fire protective U profiles
- (D) steel U-profile 20 x 40 (to be protected against fire when fire risk inside the duct)
- (E) internal or external caulking

Figure 2.1.4.3.1b: Horizontal duct composed of GEOTEC® S fire protective boards

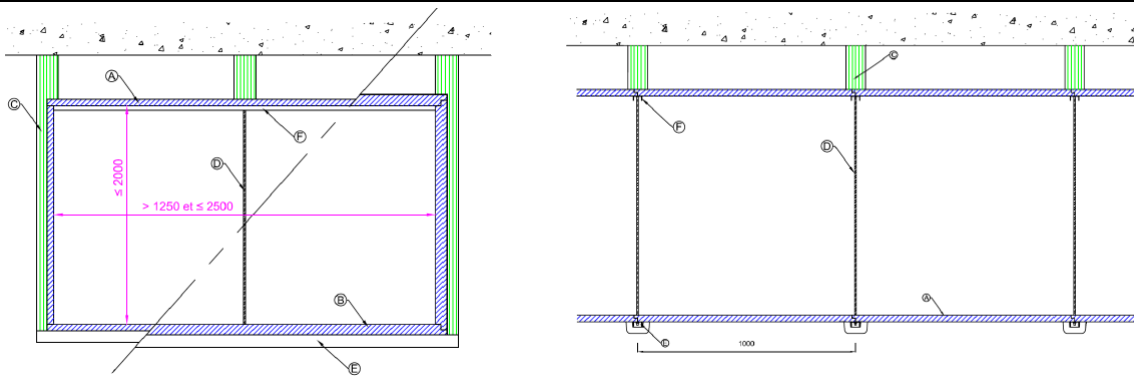

LEGEND

- (A) GEOTEC® S 30 mm
- (B) GEOTEC® S 45 mm
- (C) Steel rod Ø 8mm and GEOTEC® A or GEOFLAM® A fire protective half-shells
- (D) additional steel rod Ø 8mm (to be protected against fire when fire risk inside the duct)
- (E) steel U-profile 20 x 40 if width between 1251 mm and 2000 mm and GEOTEC® A or GEOFLAM® A fire protective U profiles
steel U-profile 41 x 41 if width greater than 2001 mm and GEOTEC® A or GEOFLAM® A fire protective U profiles
- (F) steel U-profile 20 x 40 (to be protected against fire when fire risk inside the duct)

Figure 2.1.4.3.1c: Horizontal duct composed of GEOTEC® S fire protective boards

The suspension system, placed at 1000 mm centre distance is composed of:

- Galvanized steel rods with a diameter M8. When the internal width is greater than 1251 mm a third suspension rod in the middle is required.
- Galvanized steel U-profiles – Dimensions: 20 x 40 x 20 x 2 mm or 41 X 41 X 41 x 2 mm (when the width of the duct is greater than 2001 mm). The length of these U-profiles is 50 mm longer than the external width of the duct. The profiles are placed under the joint between two sections.

The supporting structure outside the duct is protected against fire. The supporting structure inside the duct is protected against fire when the duct is expected to be exposed to fire from the inside.

Specifications for the components are given in Table A.2.1.4.3.1

Table A.2.1.4.3.1

Element	Identification	Characteristics	Mounting and fixing
Rods	Galvanized steel rods	M8	1000 mm centre distance (30 and 45 mm boards)
Steel U-profiles	Galvanized steel U-profiles	Dimensions : 20 x 40 x 20 x 2 mm or 41 X 41 X 41 x 2 mm Length : depending of the duct section	1000 mm centre distance (30 and 45 mm boards)

A.2.1.4.3.2 Insulation

The galvanized steel rods are protected with GEOTEC® A or GEOGLAM® A fire protective shells (Ø 90 mm). The shells are composed of two half-pieces applied on the rods and fixed with GEOCOL® glue.

The galvanized steel U-profiles are protected with GEOTEC® A or GEOGLAM® A fire protective U-profiles (110/100 x 55 mm). These U-profiles are placed around the steel U-profiles and fixed with GEOCOL® glue.

When fire in the duct is expected, the steel profiles in the duct have to be protected in the same way.

Specifications for the components are given in Table A.2.1.4.3.2

Table A.2.1.4.3.2

Element	Identification	Characteristics	Mounting and fixing
Half-shells	GEOTEC® A or GEOGLAM® A	Length: 1000 mm Diameter: Ø 90 mm	Placed on steel rods and maintained with GEOCOL® glue (or equivalent)
U-profile protections	GEOTEC® A or GEOGLAM® A	Length: 1000 mm Width: 110/100 mm Thickness: 55 mm	Placed on steel U-profiles and maintained with GEOCOL® glue (or equivalent)

A.2.1.4.3.3. Fire protective boards

The GEOTEC® S boards are placed to form a continuous horizontal duct (see figures 2.1.4.3.1.a, 2.1.4.3.1.b and 2.1.4.3.1.c.).

The boards are fixed together with GEOCOL® glue or equivalent at all edges and in the rabbets.

Caulking of vegetable fibre + plaster (such as GEOPLATRE N or similar) is applied on all joints (vertical and horizontal). The dimensions of this caulking is 50 mm by 10 mm on the horizontal or vertical joints and 20 mm by 20 mm in the corners.

Specifications for the components are given in Table A.2.1.4.3.3.

Table A.2.1.4.3.3

Element	Identification	Characteristics	Mounting and fixing
Board	GEOTEC® S	Thickness: 30 or 45 mm Length: 1000 mm Width: See table 2	Installed to form a rectangular horizontal duct
Glue	GEOCOL® or equivalent	Gypsum based adhesive, in powder form	Used for fixing of the board
Caulking		Mixture of vegetal fibres and bonding plaster 50 mm by 10 mm on joints or 20 mm by 20 mm in corners	All joints are completely covered at the inside or at the outside the duct

A.2.1.4.3.4: Penetration seal

The duct penetrates 110 mm (30 mm boards) or 150 mm (45 mm boards) walls through a gap, without touching the wall. The distance between the gap and the duct is never larger than 25 mm.

The gap between the penetration wall and the duct is filled up with

- mineral wool (A1 classified according to EN 13501-1, density ≥ 26 kg/m³)
- caulking made of vegetable fibres and bonding plaster (see figure 2.1.4.1.4.2)
- fire protective foam such as SIKA BOOM or SOUDAFOAM FR.

A.2.1.4.4. Vertical ducts

A.2.1.4.4.1. Supporting structure

The continuous self-supporting vertical duct is composed of GEOTEC® S fire protective boards (see paragraph A.2.1.4.4.2 for details of the duct composition). The duct penetrates floors with a minimum thickness of 110 mm (30 mm boards) or 150 mm (45 mm boards) (or a floor with an equivalent resistance to fire performance characteristics – see paragraph A.2.1.4.4.3. for details of penetration).

The vertical duct is supported by 200 mm high fillets with the same thickness as the boards to support its own weight.

When the maximum height between two load-bearing structures is less than or equal to 7 m and the ducts are composed of 4 boards, 2 fillets are glued on opposite sides of the duct. When the duct is composed of more than 4 boards, a fillet is applied to each side composed of 2 or more boards.

When the maximum height between two load-bearing structures is greater than 7 m and less than or equal to 10 m and the ducts are composed of 4 boards, 3 fillets are glued on the sides of the duct. When the duct is composed of more than 4 boards, a fillet is applied to each side composed of 2 or more boards, but at least 3 fillets.

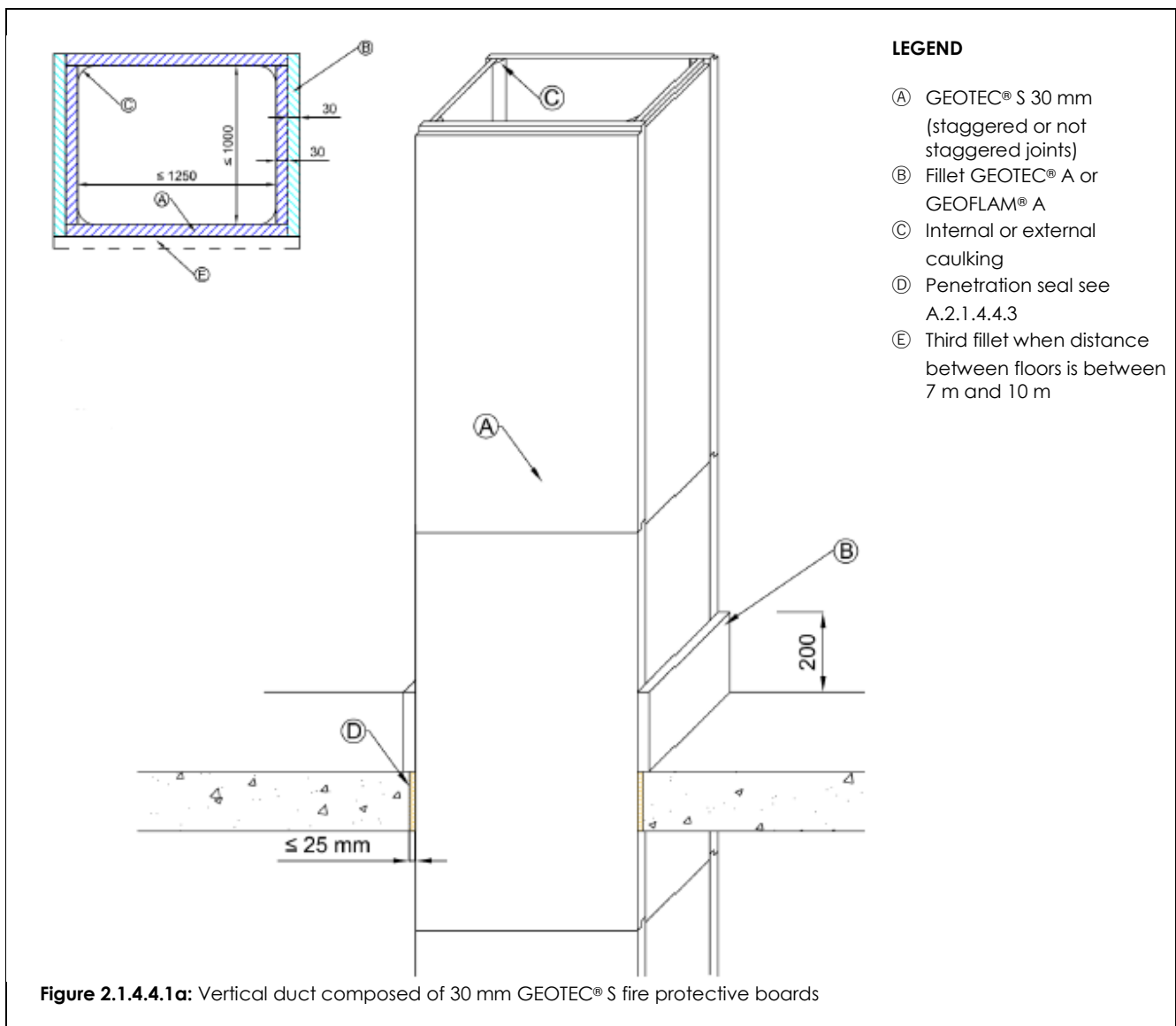

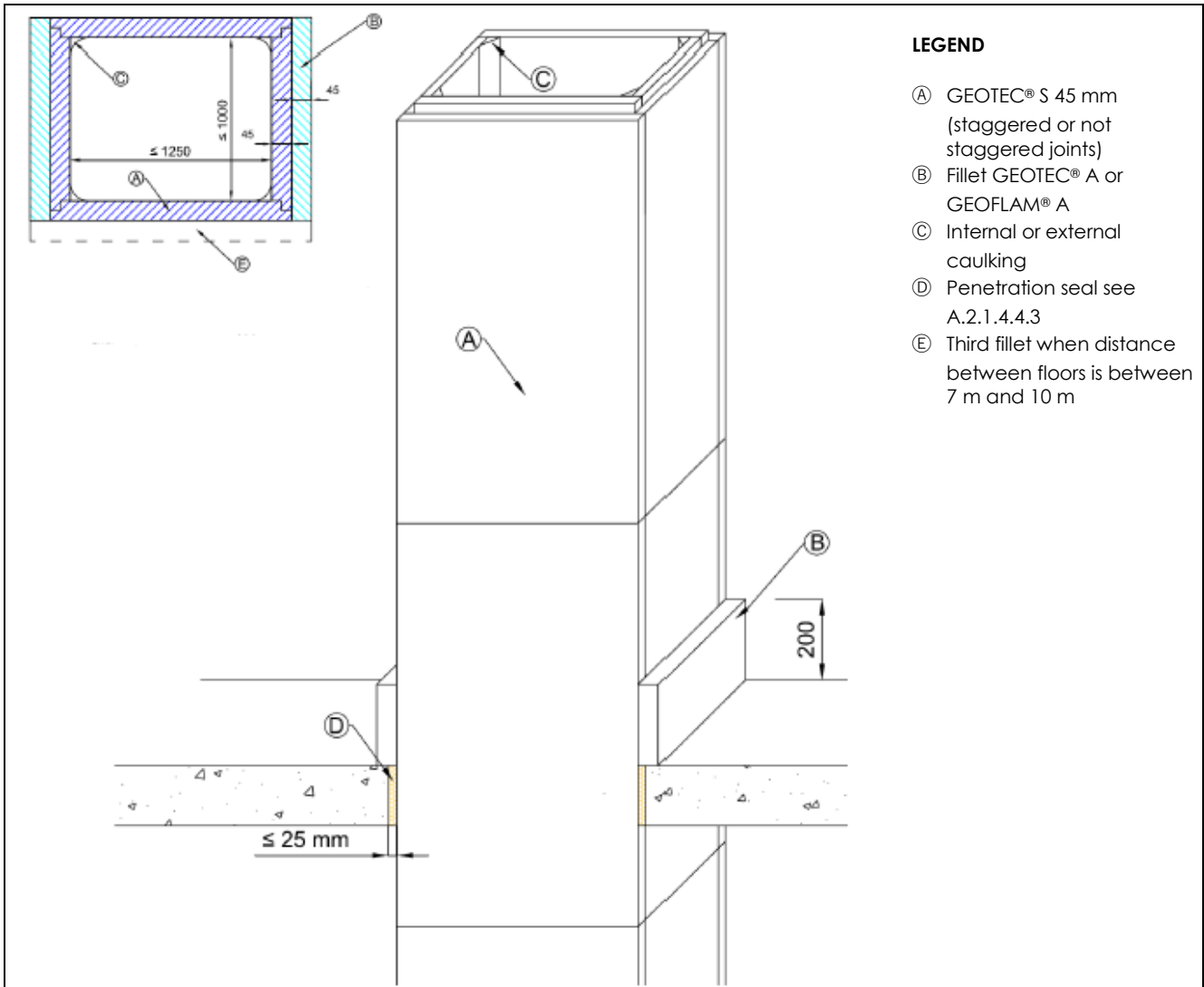

LEGEND

- Ⓐ GEOTEC® S 45 mm (staggered or not staggered joints)
- Ⓑ Fillet GEOTEC® A or GEOFLAM® A
- Ⓒ Internal or external caulking
- Ⓓ Penetration seal see A.2.1.4.4.3
- Ⓔ Third fillet when distance between floors is between 7 m and 10 m

Figure 2.1.4.4.1b: Vertical duct composed of 45 mm GEOTEC® S fire protective boards

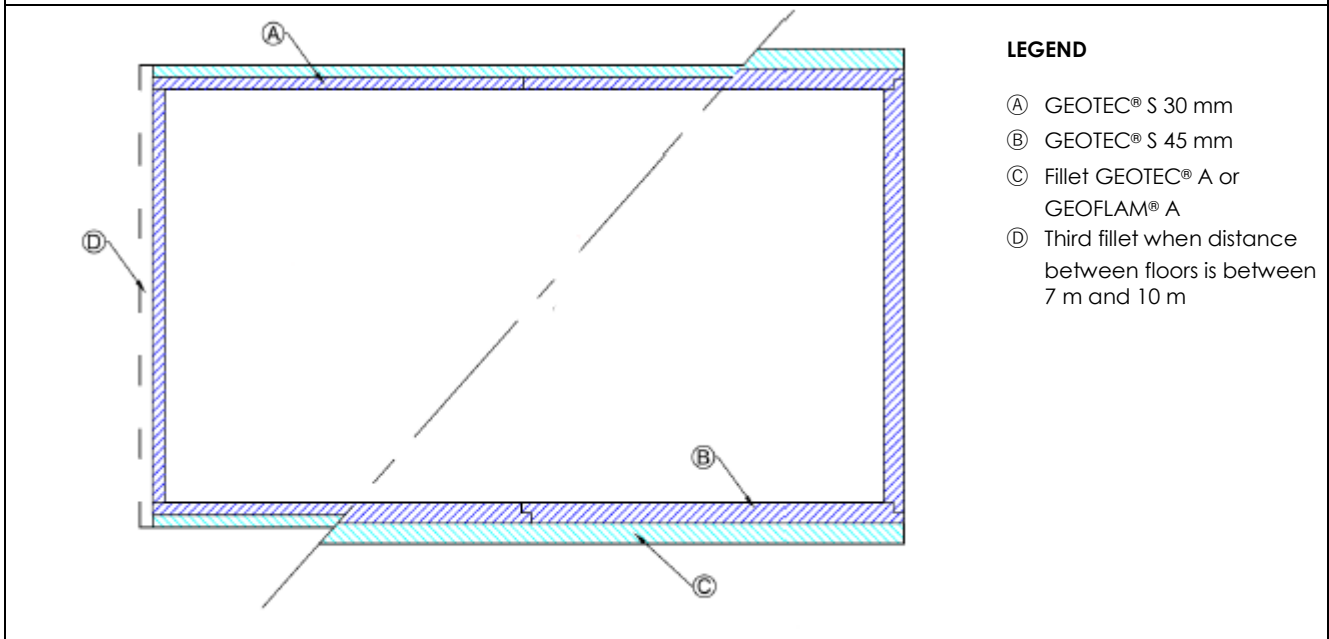

LEGEND

- Ⓐ GEOTEC® S 30 mm
- Ⓑ GEOTEC® S 45 mm
- Ⓒ Fillet GEOTEC® A or GEOFLAM® A
- Ⓓ Third fillet when distance between floors is between 7 m and 10 m

Figure 2.1.4.4.1c: Vertical duct composed of 6 or more boards, with 1 board on the short side

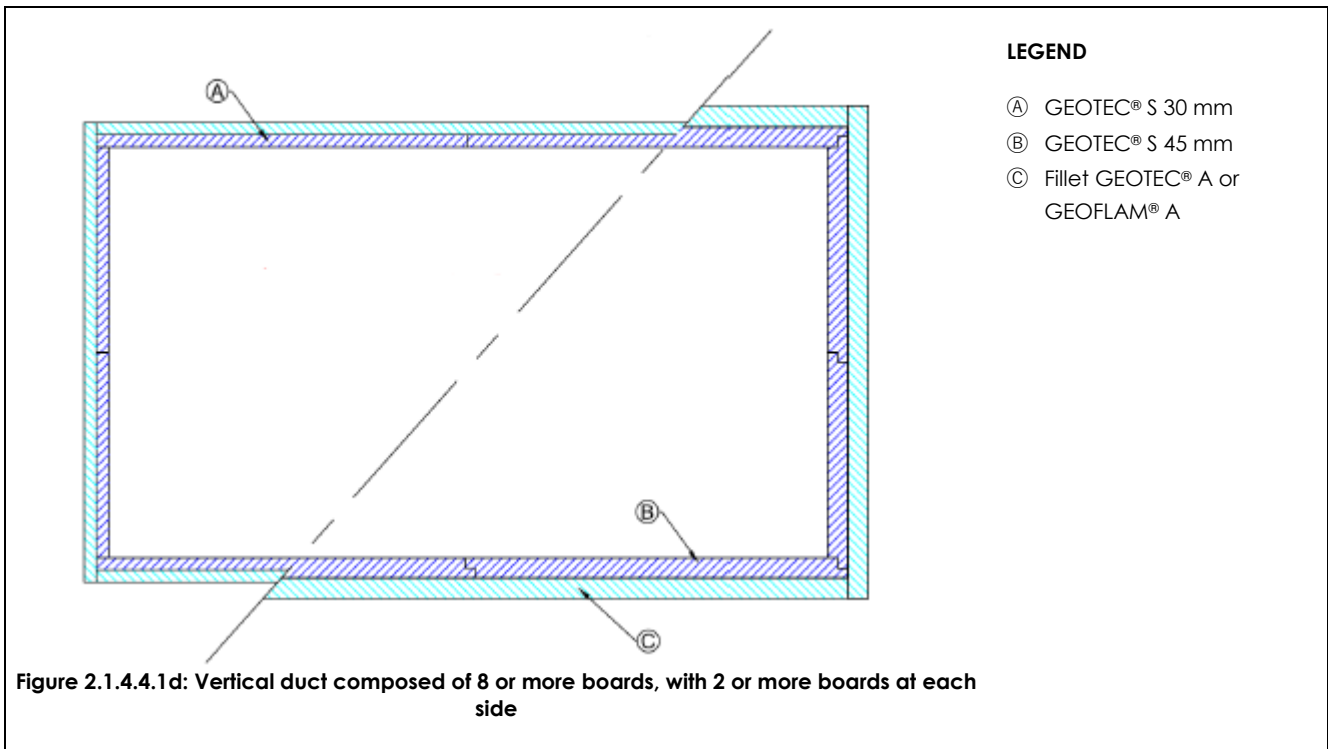

A.2.1.4.4.2. Fire protective boards

The GEOTEC® S boards are placed to form a continuous vertical duct (see figures 2.1.4.4.1.a, 2.1.4.4.1.b, 2.1.4.4.1.c and 2.1.4.4.1.d).

The boards are fixed together with GEOCOL® glue or equivalent at all edges and in the rabbets.

Caulking of vegetable fibre + plaster (such as GEOPLATRE N or similar) is applied on all joints (vertical and horizontal). The dimensions of this caulking is 50 mm by 10 mm on the horizontal or vertical joints and 20 mm by 20 mm in the corners.

Specifications for the components are given in Table A.2.1.4.4.2

Table A.2.1.4.4.2

Element	Identification	Characteristics	Mounting and fixing
Board	GEOTEC® S	Thickness: 30 or 45 mm Length: 1000 mm Width: See table 2	Installed to form a rectangular horizontal duct
Glue	GEOCOL® or equivalent	Gypsum based adhesive, in powder form	Used for fixing of the board
Caulking		Mixture of vegetal fibres and bonding plaster 50 mm by 10 mm on joints or 20 mm by 20 mm in corners	All joints are completely covered at the inside or at the outside the duct

A.2.1.4.4.3. Penetration seal

The duct penetrates 110 mm (30 mm boards) or 150 mm (45 mm boards) floors through a gap, without touching the slab. The distance between the gap and the duct is never larger than 25 mm.

The gap between the penetration wall and the duct is filled up with

- mineral wool (A1 classified according to EN 13501-1, density $\geq 26 \text{ kg/m}^3$)
- caulking made of vegetable fibres and bonding plaster (see figure 2.1.4.4.1)
- fire protective foam such as SIKA BOOM or SOUDAFOAM FR.

A.2.1.4.5 Field of direct application

The results of the fire test are directly applicable to similar constructions where one or more of the changes listed below are made and the construction continues to comply with the appropriate design code for its stiffness and stability.

- Only 4 sided ducts are covered by this classification
- Horizontal and vertical ducts according to A.2.1.4.3 and A.2.1.4.4
- The internal dimensions of the ducts are between 50 mm and 2500 mm in width by between 50 mm and 2000 mm in height.
- Vertical ducts are supported at least every 7 m or 10 m as presented in A.2.1.4.4.
- The duct may penetrate walls or floors, with a thickness superior to 110 mm (30 mm boards) or 150 mm (45 mm boards) and a density superior to 550 kg/m³

A.2.1.5. Service ducts and shafts composed of GEOTEC® S boards assembled by gluing and screwing

A.2.1.5.1. General

The horizontal and vertical service ducts are composed of GEOTEC® S boards with a thickness of 30 mm or 45 mm. The internal dimensions of the ducts are between 50 mm by 50 mm and 2500 mm (wide) by 1500 mm (high)

A.2.1.5.2. Assembly

The ducts are composed of 1000 mm sections, build up of 4 or more 30 mm or 45 mm GEOTEC® S boards. The boards are placed with the smooth face indifferently to the inside or outside of the duct and are mounted with or without a horizontal and vertical offset of the joints from one face to the other.

The 45 mm boards have 22 mm by 23 mm rabbets at the 4 sides. The 30 mm boards have 14 mm by 16 mm rabbets only on the long sides. These rabbets may ease the assembly.

After applying GEOCOL on the rabbets and edges, the boards are connected by screws Ø 5 x 80 mm (for 30 mm boards) and Ø 5 x 90 mm (for 45 mm boards). The distance between the screws is about 120 mm.

A.2.1.5.3 Horizontal ducts

A.2.1.5.3.1. Supporting structure

The continuous self-supporting horizontal duct is composed of GEOTEC® S fire protective boards (see paragraph A.2.1.5.3.3 for details of the duct composition). The duct penetrates walls with a minimum thickness of 110 mm (30 mm boards) or 150 mm (45 mm boards) (or a partition with an equivalent resistance to fire performance characteristics – see paragraph A.2.1.5.3.4. for details of penetration). The duct is supported by steel suspension system at intervals of 1000 mm (30 mm or 45 mm boards), as illustrated by figures 2.1.4.3.1.a, 2.1.4.3.1.b and 2.1.4.3.1.c. The joints of the bottom boards and the vertical boards shall not be staggered.

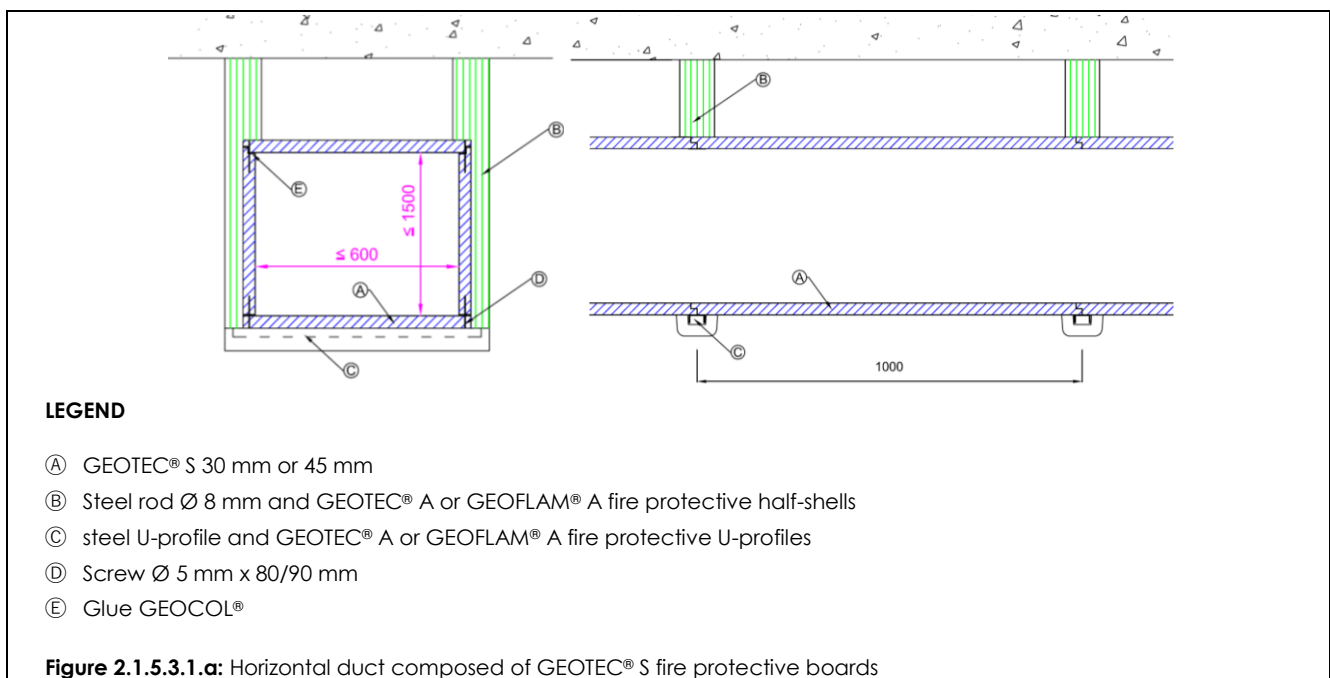

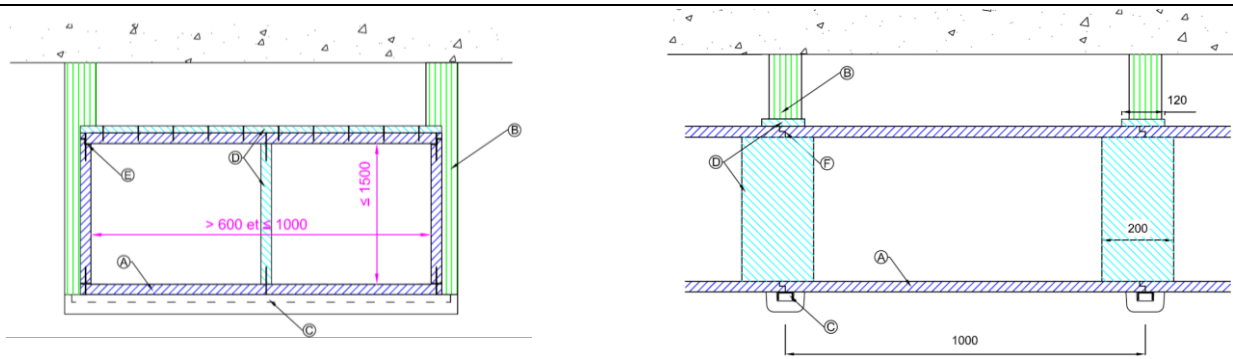

LEGEND

- (A) GEOTEC® S 30 mm or 45 mm
- (B) Steel rod Ø 8mm and GEOTEC® A or GEOFLAM® A fire protective half-shells (Rods Ø 10 mm or a third Ø 8 mm rod may apply)
- (C) steel U-profile and GEOTEC® A or GEOFLAM® A fire protective U profiles
- (D) Internal or external joint cover 120 mm by 20 mm or internal supporting structure GEOTEC® S 200 mm x 30/45 mm
- (E) Screw Ø 5 mm x 80/90 mm
- (F) Glue GEOCOL®

Figure 2.1.5.3.1.b: Horizontal duct composed of GEOTEC® S fire protective boards

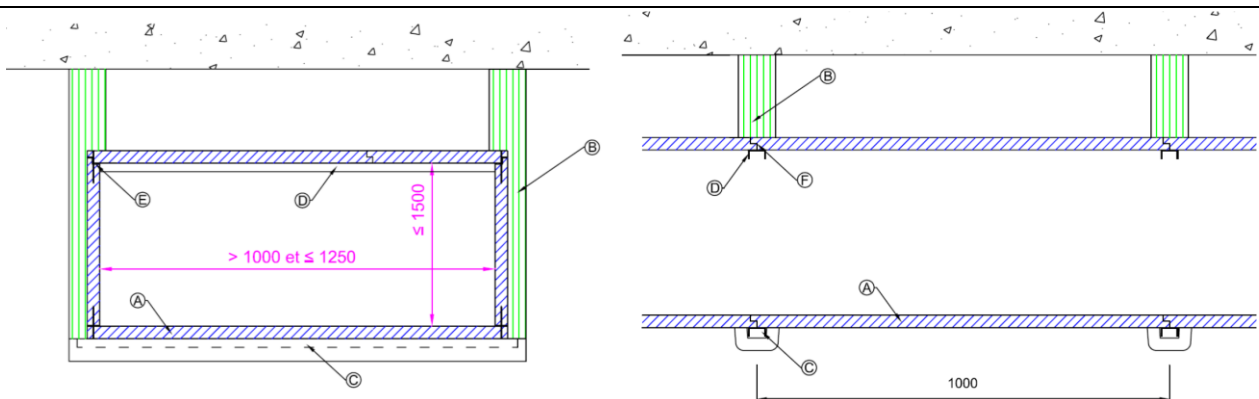

LEGEND

- (A) GEOTEC® S 30 mm/ 45 mm
- (B) Steel rod Ø 8mm and GEOTEC® A or GEOFLAM® A fire protective half-shells (Rods Ø 10 mm or a third Ø 8 mm rod may apply)
- (C) steel U-profile and GEOTEC® A or GEOFLAM® A fire protective U profiles
- (D) steel U-profile 20 x 40 (protect against fire if necessary)
- (E) Screw Ø 5 mm x 80/90 mm
- (F) Glue GEOCOL®

Figure 2.1.5.3.1.c: Horizontal duct composed of GEOTEC® S fire protective boards

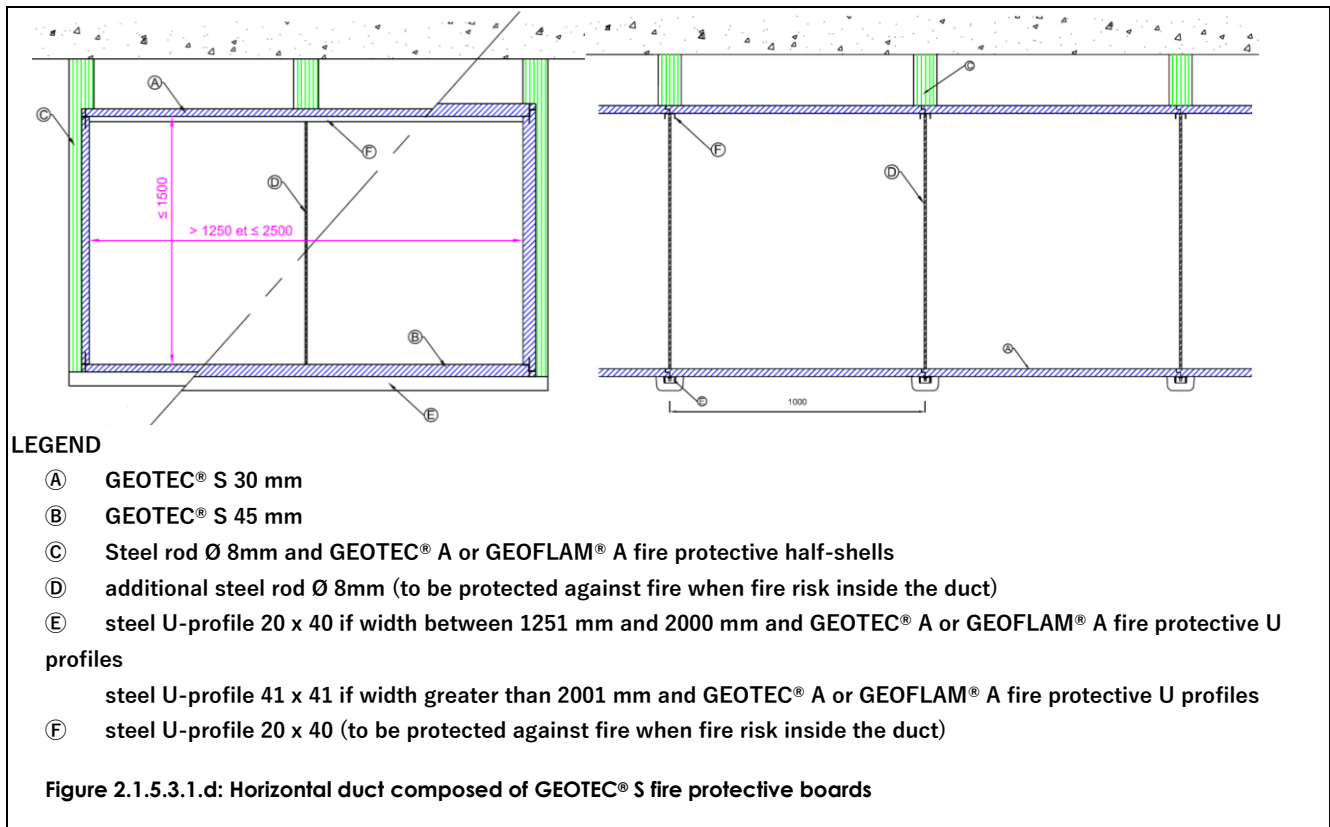

The suspension system, placed at 1000 mm centre distance is composed of:

- Galvanized steel rods with a diameter M8. When the internal perimeter of the duct exceeds 4500 mm rods with a diameter M10 are to be used or a third M8 rod is added in the middle. When the internal width is greater than 1251 mm a third suspension rod in the middle is required.
- Galvanized steel U-profiles – Dimensions: 20 x 40 x 20 x 2 mm or 41 X 41 X 41 x 2 mm (under the bottom board when the width of the duct is greater than 2001 mm). The length of these U-profiles is 50 mm longer than the external width of the duct. The profiles are placed under the joint between two sections.

The supporting structure outside the duct is protected against fire. The supporting structure inside the duct is protected against fire when the duct is expected to be exposed to fire from the inside.

Specifications for the components are given in Table A.2.1.5.3.1

Table A.2.1.5.3.1

Element	Identification	Characteristics	Mounting and fixing
Rods	Galvanized steel rods	M8 or M10	1000 mm centre distance (30 and 45 mm boards)
Steel U-profiles	Galvanized steel U-profiles	Dimensions : 20 x 40 x 20 x 2 mm or 41 X 41 X 41 x 2 mm Length : depending of the duct section	1000 mm centre distance (30 and 45 mm boards)

A.2.1.5.3.2. Stiffeners

Ducts with a width smaller than 600 mm, regardless the height of the duct, do not need an internal stiffener nor a joint cover.

For ducts with a width between 601 mm and 1000 mm, two options are available for insuring the tightness of the joints :

- A joint cover, with a section of 120 mm by 20 mm, made of GEOTEC® S board, is fixed to the upper board of the duct with Ø 5 x 50 mm screws, covering the transversal joint. The distance between the screws is about 120 mm. The joint cover may be placed at the inside or at the outside of the duct.
- An internally placed 200 mm wide stiffener, made of GEOTEC® S board of the same thickness as the duct, and installed in the middle of the duct, under each joint in the top boards. The stiffeners are fixed to the bottom and top boards with Ø 5 x 80 mm screws. The distance between the screws is about 120 mm.

When the internal perimeter of the duct exceeds 4500 mm and the solution of a third rod in the middle of the span is chosen, and this rod is protected by 2 half-shells GEOTEC® A or GEOGLAM® A, this assembly may also assure the tightness and the stability of the top board.

For ducts with a width between 1001 mm and 2500 mm, the stability of the top boards is assured by the suspension system.

A.2.1.5.3.2 Insulation

The galvanized steel rods are protected with GEOTEC® A or GEOGLAM® A fire protective shells (Ø 90 mm). The shells are composed of two half-pieces applied on the rods and fixed with GEOCOL® glue.

The galvanized steel U-profiles are protected with GEOTEC® A or GEOGLAM® A fire protective U-profiles (110/100 x 55 mm). These U-profiles are placed around the steel U-profiles and fixed with GEOCOL® glue.

When fire in the duct is expected, the steel profiles in the duct have to be protected in the same way.

Specifications for the components are given in Table A.2.1.5.3.2

Table A.2.1.5.3.2

Element	Identification	Characteristics	Mounting and fixing
Half-shells	GEOTEC® A or GEOGLAM® A	Length: 1000 mm Diameter: Ø 90 mm	Placed on steel rods and maintained with GEOCOL® glue (or equivalent)
U-profile protections	GEOTEC® A or GEOGLAM® A	Length: 1000 mm Width: 110/100 mm Thickness: 55 mm	Placed on steel U-profiles and maintained with GEOCOL® glue (or equivalent)

A.2.1.5.3.3. Fire protective boards

The GEOTEC® S boards are placed to form a continuous horizontal duct (see figures 2.1.4.3.1.a, 2.1.4.3.1.b and 2.1.4.3.1.c.).

The boards are fixed together with GEOCOL® glue or equivalent at all edges and in the rabbets and screwed, using Ø 5 x 80 mm or Ø 5 x 90 mm screws.

Specifications for the components are given in Table A.2.1.5.3.3.

Table A.2.1.5.3.3

Element	Identification	Characteristics	Mounting and fixing
Board	GEOTEC® S	Thickness: 30 or 45 mm Length: 1000 mm 4 Width: See table 2	Installed to form a rectangular horizontal duct
Glue	GEOCOL® or equivalent	Gypsum based adhesive, in powder form	Used for fixing of the board
Screws	Wood and chipboard screw	Ø 5 x 80 mm for 30 mm boards Ø 5 x 90 mm for 45 mm boards	Centre distance 120 mm

A.2.1.5.3.4: Penetration seal

The duct penetrates 110 mm (30 mm boards) or 150 mm (45 mm boards) walls through a gap, without touching the wall. The distance between the gap and the duct is never larger than 25 mm.

The gap between the penetration wall and the duct is filled up with

- mineral wool (A1 classified according to EN 13501-1, density ≥ 26 kg/m³)
- fire protective foam such as SIKA BOOM or SOUDAFOAM FR.

The penetration may be protected with a layer of GEOCOL, applied to the penetration and the duct surface, to assure a tight seal.

A.2.1.5.4. Vertical ducts

A.2.1.5.4.1. Supporting structure

The continuous self-supporting vertical duct is composed of GEOTEC® S fire protective boards (see paragraph A.2.1.5.4.2 for details of the duct composition). The duct penetrates floors with a minimum thickness of 110 mm (30 mm boards) or 150 mm (45 mm boards) (or a floor with an equivalent resistance to fire performance characteristics – see paragraph A.2.1.5.4.3. for details of penetration). Boards are placed staggered between 200 mm and 800 mm

The vertical duct is supported by 200 mm high fillets with the same thickness as the boards to support its own weight.

For distances between the supports less than 7 m and ducts composed of 4 boards, 2 fillets are glued with GEOCOL and screwed, using Ø 5 x 50 mm or Ø 5 x 80 mm screws, on opposite sides of the duct. Screws are placed on 2 rows, at 100 mm distance from each other. When the duct is composed of more than 4 boards, a fillet is applied to each side composed of 2 or more boards.

When the distance between the supports is between 7 m and 10 m and ducts composed of 4 boards, 3 fillets are glued with GEOCOL and screwed, using Ø 5 x 50 mm for 30 mm boards or Ø 5 x 80 mm screws for 45 mm boards. When the duct is composed of more than 4 boards, a fillet is applied to each side composed of 2 or more boards, but at least 3 fillets.

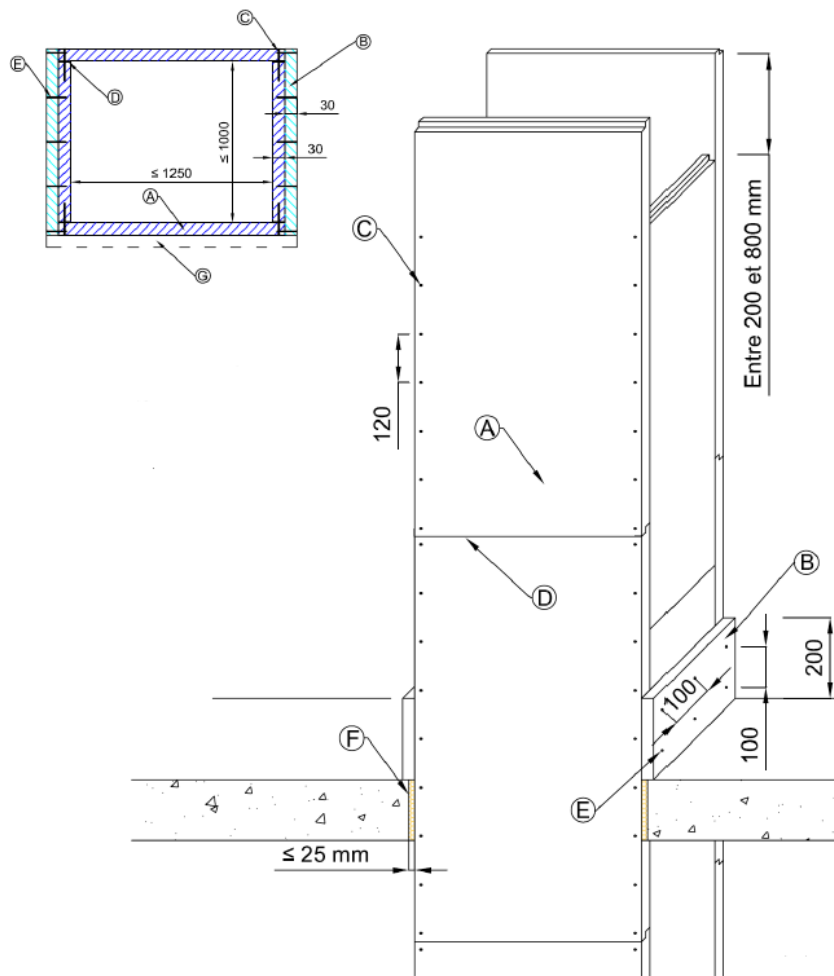

LEGEND

- (A) GEOTEC® S 30 mm (staggered joints)
- (B) Fillet GEOTEC® A or GEOFLAM® A
- (C) Screw Ø 5 x 80
- (D) Glue GEOCOL®
- (E) Screw Ø 5 x 50
- (F) Penetration seal see A.2.1.5.4.3
- (G) Third fillet when distance between floors is between 7 m and 10 m

Figure 2.1.5.4.1a: Vertical duct composed of 30 mm GEOTEC® S fire protective boards

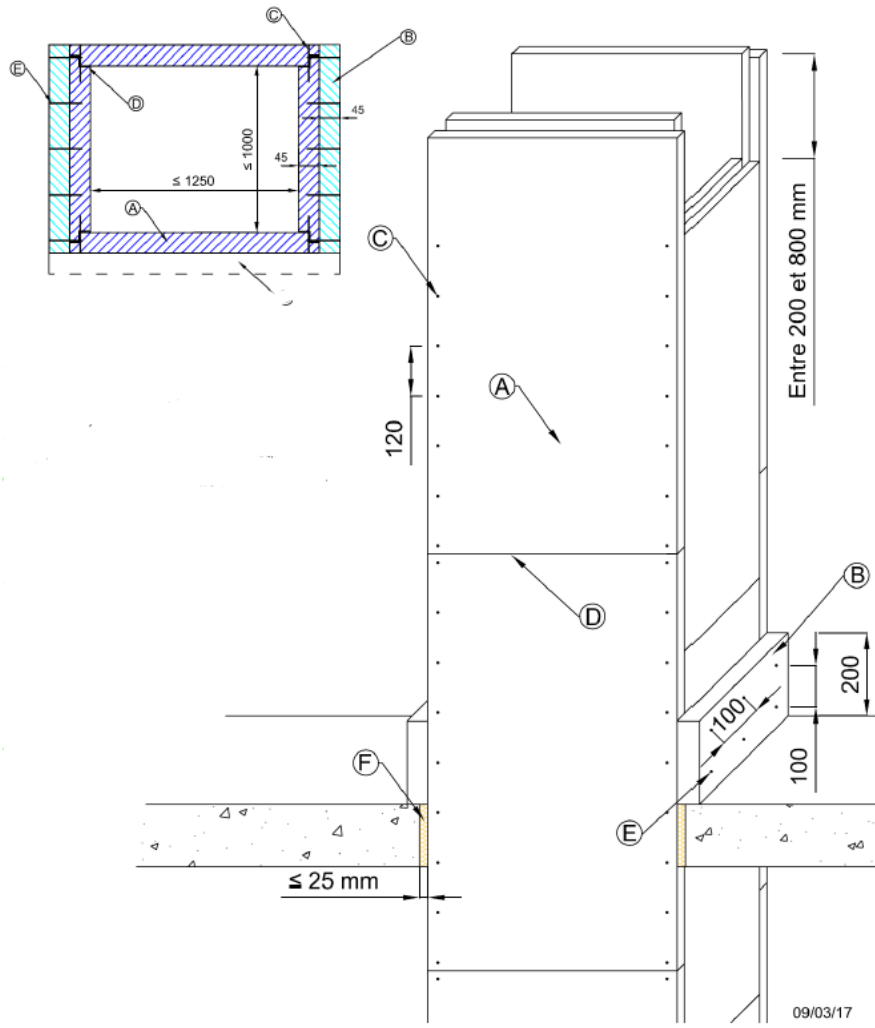

LEGEND

- Ⓐ GEOTEC® S 45 mm (staggered joints)
- Ⓑ Fillet GEOTEC® A or GEOFLAM® A
- Ⓒ Screw Ø 5 x 90
- Ⓓ Glue GEOCOL®
- Ⓔ Screw Ø 5 x 80
- Ⓕ Penetration seal see A.2.1.5.4.3
- Ⓖ Third fillet when distance between floors is between 7 m and 10 m

Figure 2.1.5.4.1b: Vertical duct composed of 45 mm GEOTEC® S fire protective boards

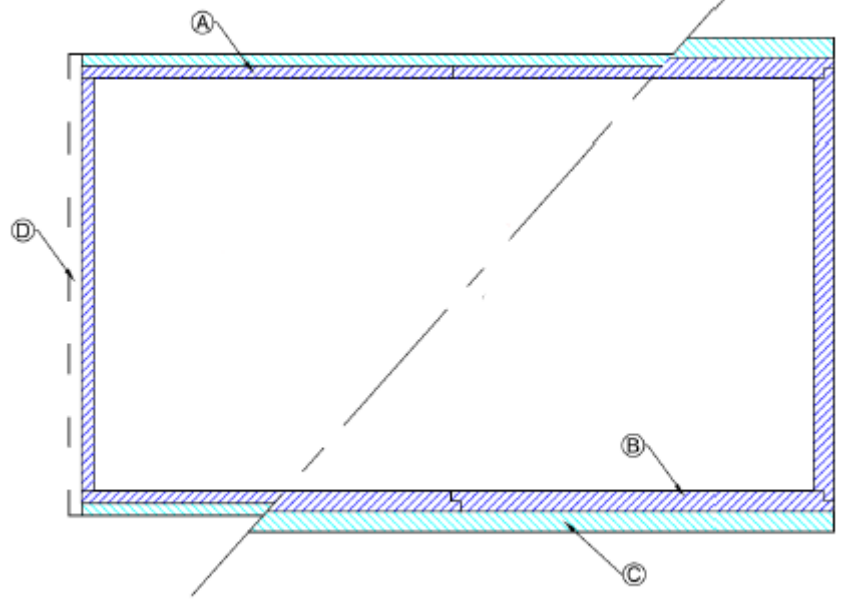

LEGEND

- Ⓐ GEOTEC® S 30 mm
- Ⓑ GEOTEC® S 45 mm
- Ⓒ Fillet GEOTEC® A or GEOFLAM® A
- Ⓓ Third fillet when distance between floors is between 7 m and 10 m

Figure 2.1.5.4.1c: Vertical duct composed of 6 or more boards, with 1 board on the short side

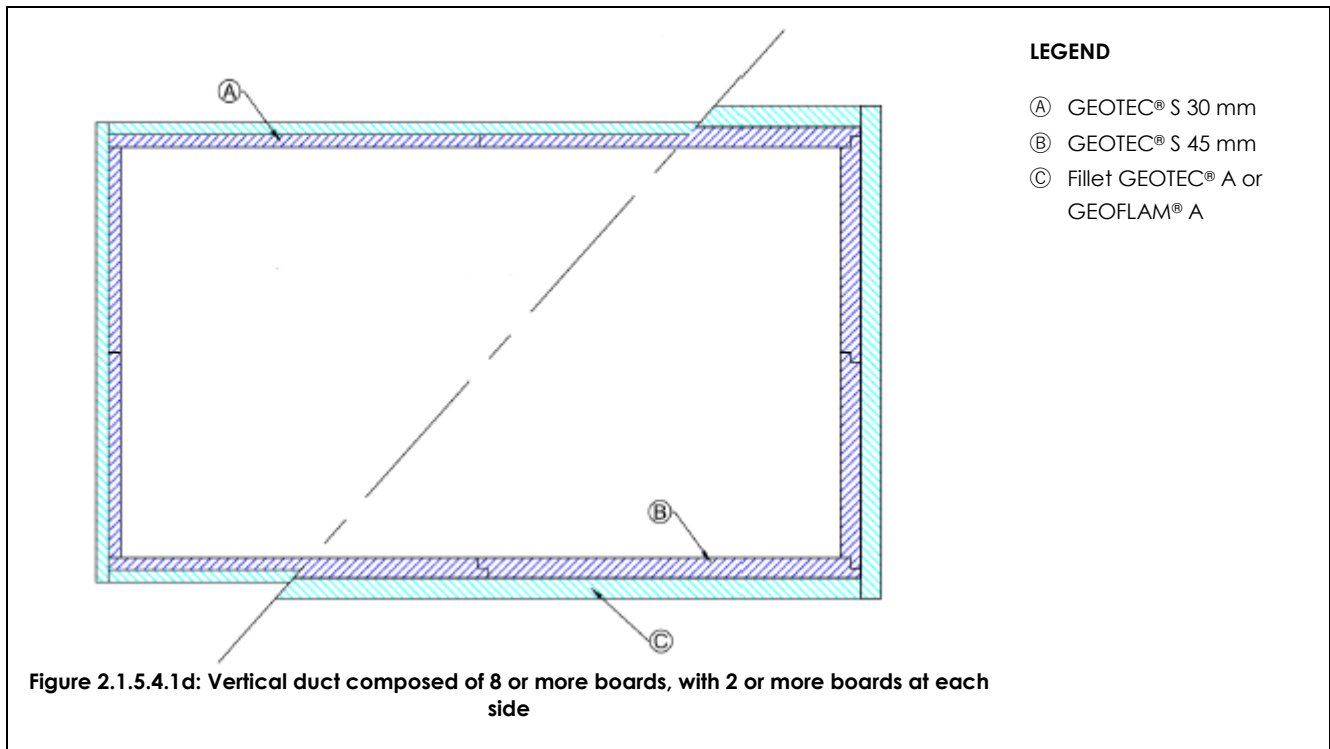

A.2.1.5.4.2. Fire protective boards

The GEOTEC® S boards are placed to form a continuous vertical duct (see figures 2.1.5.4.1.a, 2.1.5.4.1.b, 2.1.5.4.1.c and 2.1.5.4.1.d).

The boards are fixed together with GEOCOL® glue or equivalent at all edges and in the rabbets and screwed, using Ø 5 x 80 mm or Ø 5 x 90 mm screws.

Specifications for the components are given in Table A.2.1.5.4.2

Table A.2.1.5.4.2

Element	Identification	Characteristics	Mounting and fixing
Board	GEOTEC® S	Thickness: 30 or 45 mm Length: 1000 mm 4 Width: See table 2	Installed to form a rectangular horizontal duct
Glue	GEOCOL® or equivalent	Gypsum based adhesive, in powder form	Used for fixing of the board
Screws	Wood and chipboard screw	Ø 5 x 80 mm for 30 mm boards Ø 5 x 90 mm for 45 mm boards	Centre distance 120 mm

A.2.1.5.4.3. Penetration seal

The duct penetrates 110 mm (30 mm boards) or 150 mm (45 mm boards) floors through a gap, without touching the slab. The distance between the gap and the duct is never larger than 25 mm.

The gap between the penetration wall and the duct is filled up with

- mineral wool (A1 classified according to EN 13501-1, density ≥ 26 kg/m³)
- fire protective foam such as SIKA BOOM or SOUDAFOAM FR.

The penetration may be protected with a layer of GEOCOL, applied to the penetration and the duct surface, to assure a tight seal.

A.2.1.5.5 Field of direct application

The results of the fire test are directly applicable to similar constructions where one or more of the changes listed below are made and the construction continues to comply with the appropriate design code for its stiffness and stability.

- Only 4 sided ducts are covered by this classification
- Horizontal and vertical ducts according to A.2.1.5.3 an A.2.1.5.4
- The internal dimensions of the ducts are between 50 mm and 2500 mm in width by between 50 mm and 1500 mm in height.
- Vertical ducts are supported at least every 7 m or 10 m as presented in A.2.1.5.4.
- The duct may penetrate walls or floors, with a thickness superior to 110 mm (30 mm boards) or 150 mm (45 mm boards) and a density superior to 550 kg/m³

Annex 2.2: Specification of ventilation ducts (intended use type 9), composed of GEOTEC® S fire protective boards,

A.2.2.1 Date of addition to this ETA

This annex was added to ETA 18/0343 on 2018-06-12. This assembly was not covered by this ETA prior to the addition of this annex.

A.2.2.2 Classification

The assembly described in this annex has been tested according to EN 1366-1 and classified (see table A.2.0.1) in accordance with EN 13501-3.

30 mm boards : **EI 60 ve ho i ↔ o S**

45 mm boards : **EI 120 ve ho i ↔ o S**

A.2.2.3 Installation requirements

Installation requirements in paragraph 2.2 of this ETA shall be taken into account.

A.2.2.4. Ventilation ducts and shafts composed of GEOTEC® S boards assembled by caulking

A.2.2.4.1. General

The horizontal and vertical ventilation ducts are composed of GEOTEC® S boards with a thickness of 30 mm or 45 mm. The internal dimensions of the ducts are between 0 mm by 0 mm and 2500 mm (wide) by 2000 mm (high)

A.2.2.4.2. Assembly

The ducts are composed of 1000 mm long sections, build up of 4 or more 30 mm or 45 mm GEOTEC® S boards. The boards are placed with the smooth face indifferently to the inside or outside of the duct and are mounted with or without a horizontal and vertical offset of the joints from one face to the other.

The 45 mm boards have 22 mm by 23 mm rabbets at the 4 sides. The 30 mm boards have 14 mm by 16 mm rabbets only on the long sides. These rabbets may ease the assembly.

Caulking of vegetable fibre + plaster (such as GEOPLATRE N or similar) is applied on all joints (vertical and horizontal). The dimensions of this caulking is 50 mm by 10 mm on the horizontal or vertical joints and 20 mm by 20 mm in the corners.

A.2.2.4.3 Horizontal ducts

A.2.2.4.3.1. Supporting structure

The continuous self-supporting horizontal duct is composed of GEOTEC® S fire protective boards (see paragraph A.2.2.4.3.3 for details of the duct composition). The duct penetrates walls with a minimum thickness of 110 mm (30 mm boards) or 150 mm (45 mm boards) (or a partition with an equivalent resistance to fire performance characteristics – see paragraph A.2.2.4.3.4. for details of penetration). The duct is supported by steel suspension system at intervals of 1000 mm (30 mm or 45 mm boards), as illustrated by figures 2.2.4.3.1.a, 2.2.4.3.1.b and 2.2.4.3.1.c.

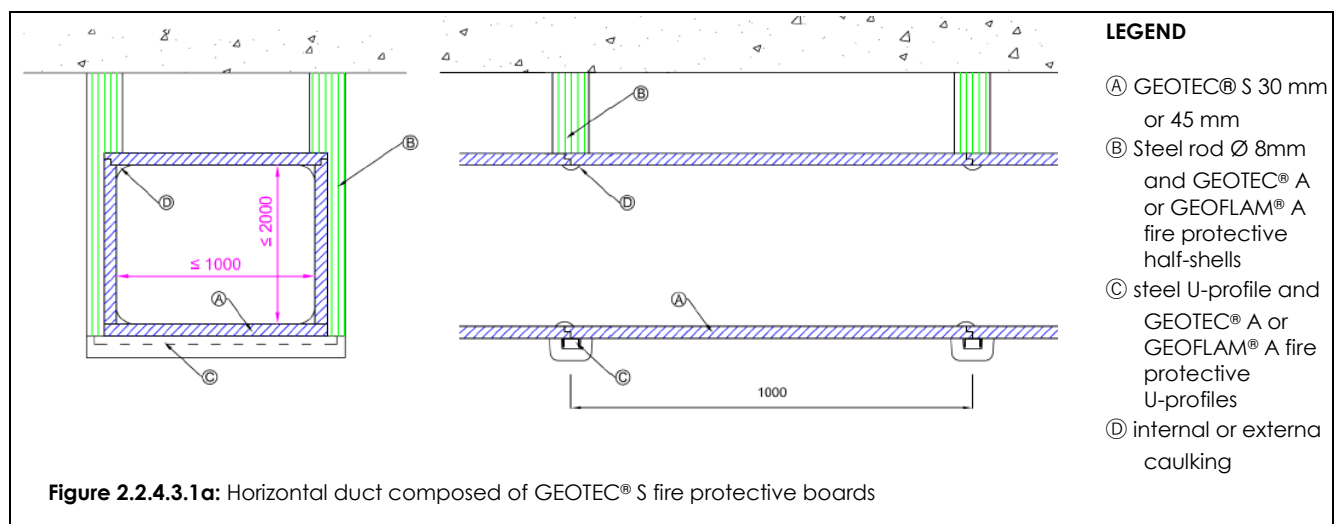

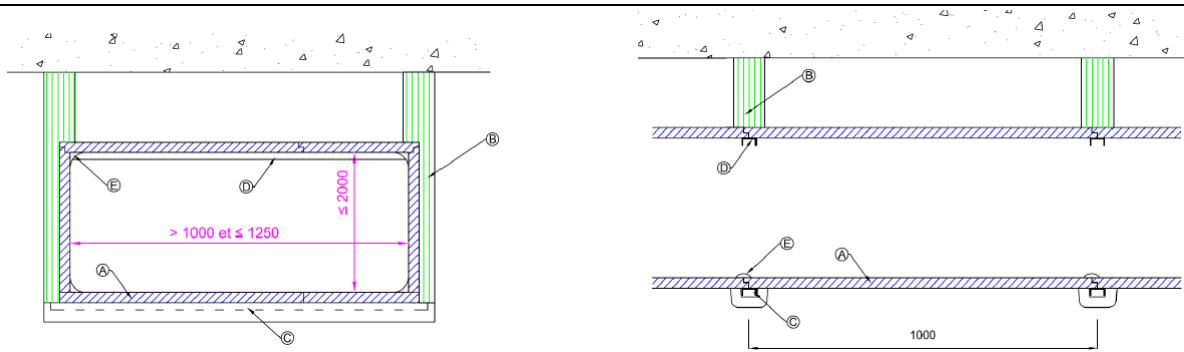

LEGEND

- (A) GEOTEC® S 30 mm or 45 mm
- (B) Steel rod Ø 8mm and GEOTEC® A or GEOFLAM® A fire protective half-shells
- (C) steel U-profile and GEOTEC® A or GEOFLAM® A fire protective U profiles
- (D) steel U-profile 20 x 40 (to be protected against fire when fire risk inside the duct)
- (E) internal or external caulking

Figure 2.2.4.3.1b: Horizontal duct composed of GEOTEC® S fire protective boards

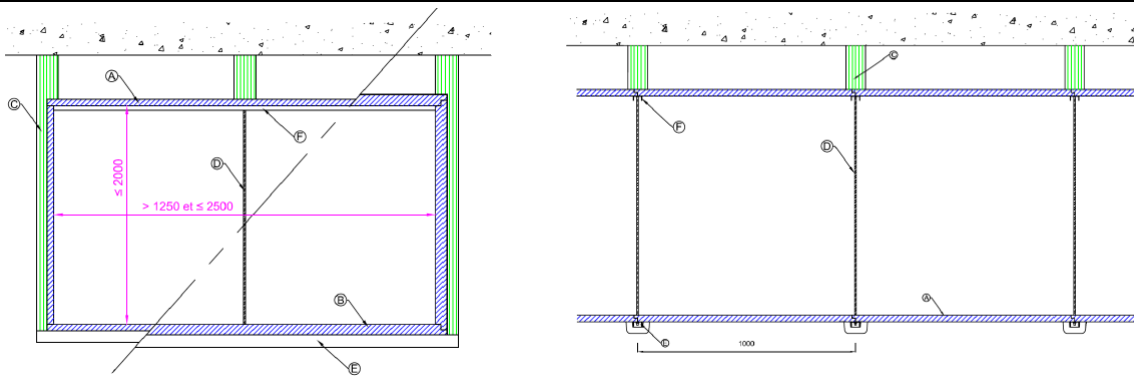

LEGEND

- (A) GEOTEC® S 30 mm
- (B) GEOTEC® S 45 mm
- (C) Steel rod Ø 8mm and GEOTEC® A or GEOFLAM® A fire protective half-shells
- (D) additional steel rod Ø 8mm (to be protected against fire when fire risk inside the duct)
- (E) steel U-profile 20 x 40 if width between 1251 mm and 2000 mm and GEOTEC® A or GEOFLAM® A fire protective U profiles
- (F) steel U-profile 41 x 41 if width greater than 2001 mm and GEOTEC® A or GEOFLAM® A fire protective U profiles
- (G) steel U-profile 20 x 40 (to be protected against fire when fire risk inside the duct)

Figure 2.2.4.3.1c: Horizontal duct composed of GEOTEC® S fire protective boards

The suspension system, placed at 1000 mm centre distance is composed of:

- Galvanized steel rods with a diameter M8. When the internal width is greater than 1251 mm a third suspension rod in the middle is required.
- Galvanized steel U-profiles – Dimensions: 20 x 40 x 20 x 2 mm or 41 X 41 X 41 x 2 mm (when the width of the duct is greater than 2001 mm). The length of these U-profiles is 50 mm longer than the external width of the duct. The profiles are placed under the joint between two sections.

The supporting structure outside the duct is protected against fire. The supporting structure inside the duct is protected against fire when the duct is expected to be exposed to fire from the inside.

Specifications for the components are given in Table A.2.2.4.3.1

Table A.2.2.4.3.1

Element	Identification	Characteristics	Mounting and fixing
Rods	Galvanized steel rods	M8	1000 mm centre distance (30 and 45 mm boards)
Steel U-profiles	Galvanized steel U-profiles	Dimensions : 20 x 40 x 20 x 2 mm or 41 X 41 X 41 x 2 mm Length : depending of the duct section	1000 mm centre distance (30 and 45 mm boards)

A.2.2.4.3.2 Insulation

The galvanized steel rods are protected with GEOTEC® A or GEOGLAM® A fire protective shells (Ø 90 mm). The shells are composed of two half-pieces applied on the rods and fixed with GEOCOL® glue.

The galvanized steel U-profiles are protected with GEOTEC® A or GEOGLAM® A fire protective U-profiles (110/100 x 55 mm). These U-profiles are placed around the steel U-profiles and fixed with GEOCOL® glue.

When fire in the duct is expected, the steel profiles in the duct have to be protected in the same way.

Specifications for the components are given in Table A.2.2.4.3.2

Table A.2.2.4.3.2

Element	Identification	Characteristics	Mounting and fixing
Half-shells	GEOTEC® A or GEOGLAM® A	Length: 1000 mm Diameter: Ø 90 mm	Placed on steel rods and maintained with GEOCOL® glue (or equivalent)
U-profile protections	GEOTEC® A or GEOGLAM® A	Length: 1000 mm Width: 110/100 mm Thickness: 55 mm	Placed on steel U-profiles and maintained with GEOCOL® glue (or equivalent)

A.2.2.4.3.3. Fire protective boards

The GEOTEC® S boards are placed to form a continuous horizontal duct (see figures 2.1.4.3.1.a, 2.1.4.3.1.b and 2.1.4.3.1.c.).

The boards are fixed together with GEOCOL® glue or equivalent at all edges and in the rabbets.

Caulking of vegetable fibre + plaster (such as GEOPLATRE N or similar) is applied on all joints (vertical and horizontal). The dimensions of this caulking is 50 mm by 10 mm on the horizontal or vertical joints and 20 mm by 20 mm in the corners.

Specifications for the components are given in Table A.2.2.4.3.3.

Table A.2.2.4.3.3

Element	Identification	Characteristics	Mounting and fixing
Board	GEOTEC® S	Thickness: 30 or 45 mm Length: 1000 mm Width: See table 2	Installed to form a rectangular horizontal duct
Glue	GEOCOL® or equivalent	Gypsum based adhesive, in powder form	Used for fixing of the board
Caulking		Mixture of vegetal fibres and bonding plaster 50 mm by 10 mm on joints or 20 mm by 20 mm in corners	All joints are completely covered at the inside or at the outside the duct

A.2.2.4.3.4: Penetration seal

The duct penetrates 110 mm (30 mm boards) or 150 mm (45 mm boards) walls through a gap, without touching the wall. The distance between the gap and the duct is never larger than 25 mm.

The gap between the penetration wall and the duct is filled up with

- mineral wool (A1 classified according to EN 13501-1, density ≥ 26 kg/m³)
- caulking made of vegetable fibres and bonding plaster (see figure 2.1.4.1.4.2)
- fire protective foam such as SIKABOOM or SOUDAFOAM FR.

A.2.2.4.4. Vertical ducts

A.2.2.4.4.1. Supporting structure

The continuous self-supporting vertical duct is composed of GEOTEC® S fire protective boards (see paragraph A.2.2.4.4.2 for details of the duct composition). The duct penetrates floors with a minimum thickness of 110 mm (30 mm boards) or 150 mm (45 mm boards) (or a floor with an equivalent resistance to fire performance characteristics – see paragraph A.2.2.4.4.3. for details of penetration).

The vertical duct is supported by 200 mm high fillets with the same thickness as the boards to support its own weight.

For distances between the supports less than 7 m and ducts composed of 4 boards, 2 fillets are glued on opposite sides of the duct. When the duct is composed of more than 4 boards, a fillet is applied to each side composed of 2 or more boards.

When the distance between the supports is between 7 m and 10 m and ducts composed of 4 boards, 3 fillets are glued on the sides of the duct. When the duct is composed of more than 4 boards, a fillet is applied to each side composed of 2 or more boards, but at least 3 fillets.

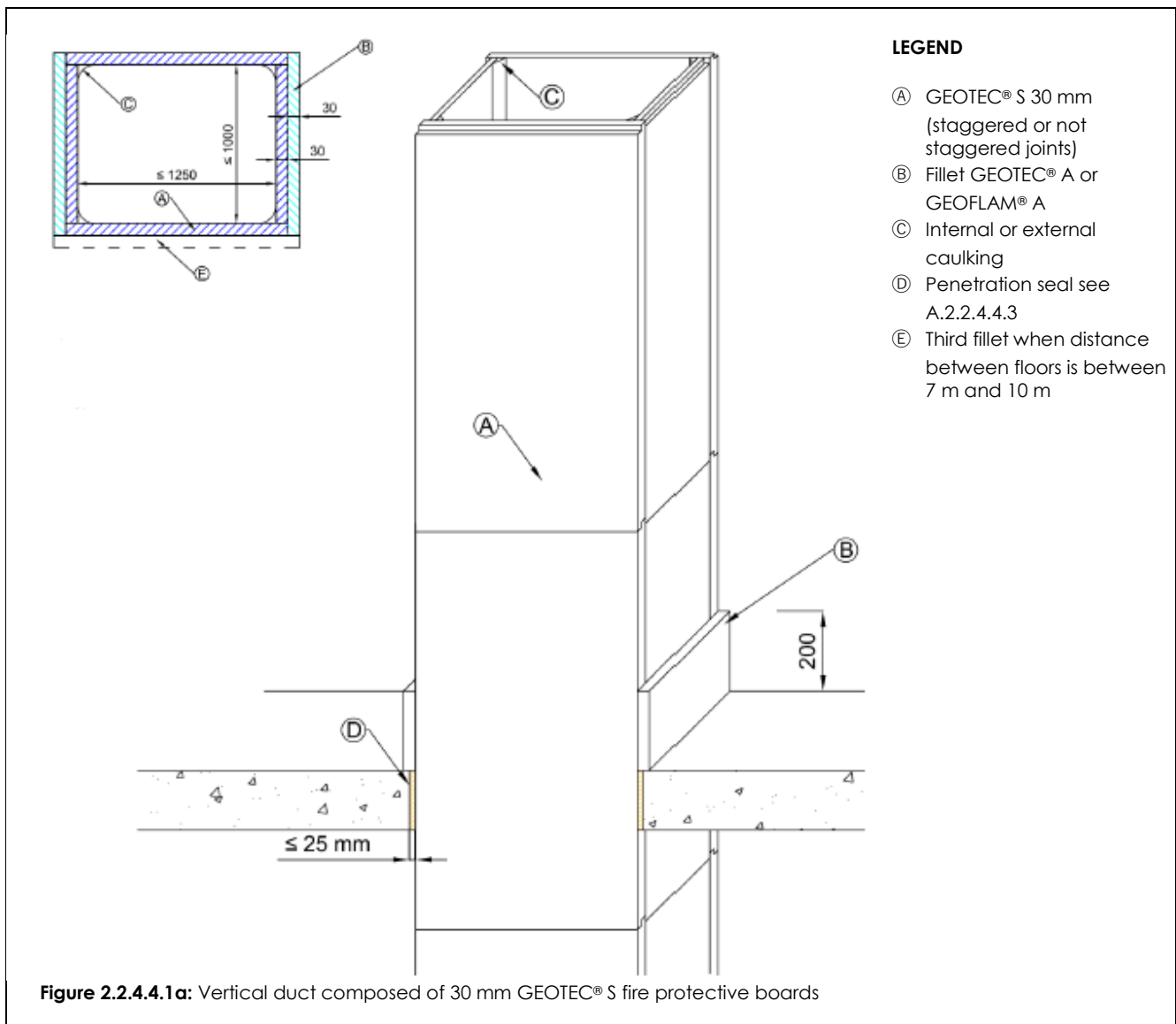

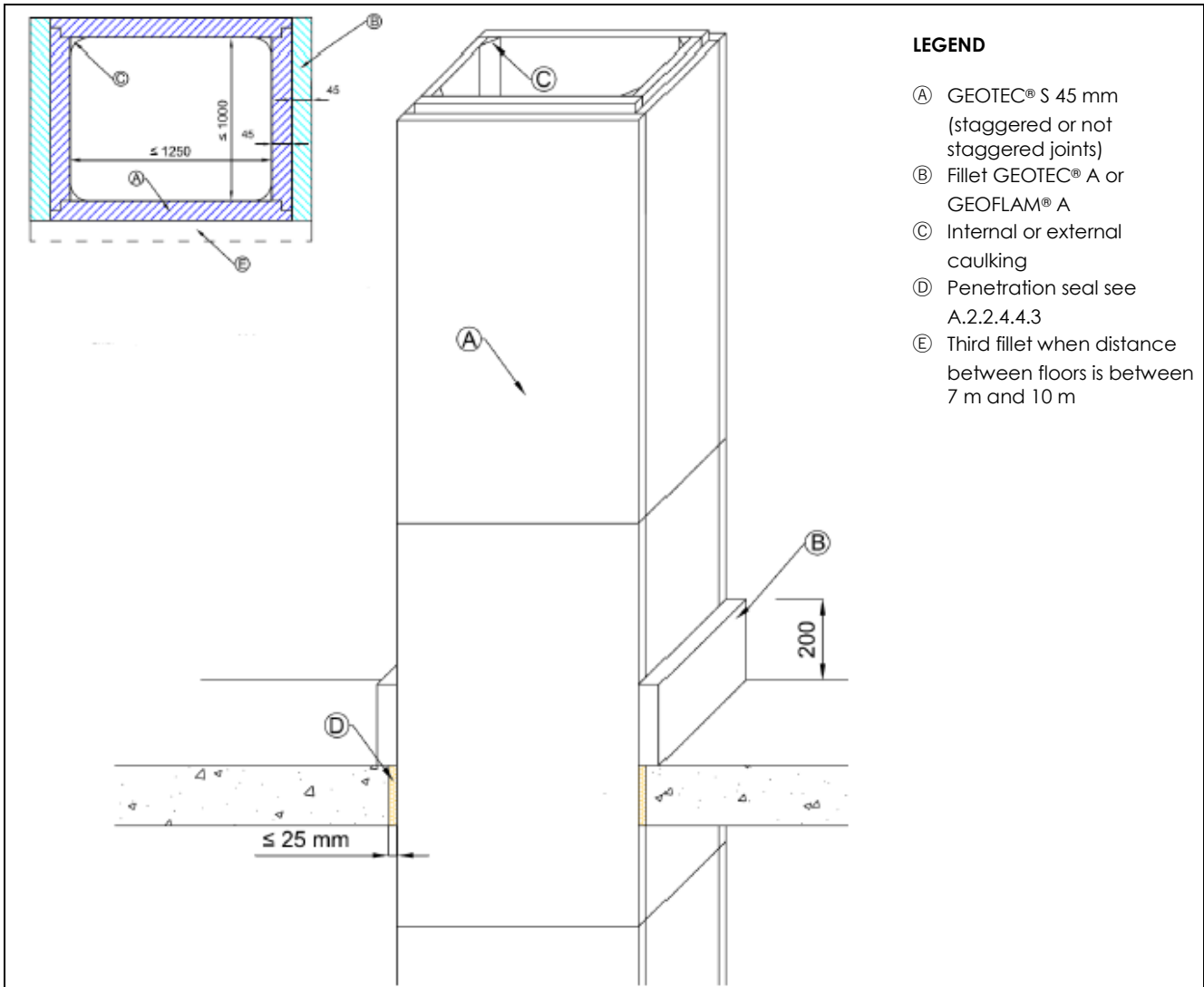

LEGEND

- Ⓐ GEOTEC® S 45 mm (staggered or not staggered joints)
- Ⓑ Fillet GEOTEC® A or GEOFLAM® A
- Ⓒ Internal or external caulking
- Ⓓ Penetration seal see A.2.2.4.4.3
- Ⓔ Third fillet when distance between floors is between 7 m and 10 m

Figure 2.2.4.4.1b: Vertical duct composed of 45 mm GEOTEC® S fire protective boards

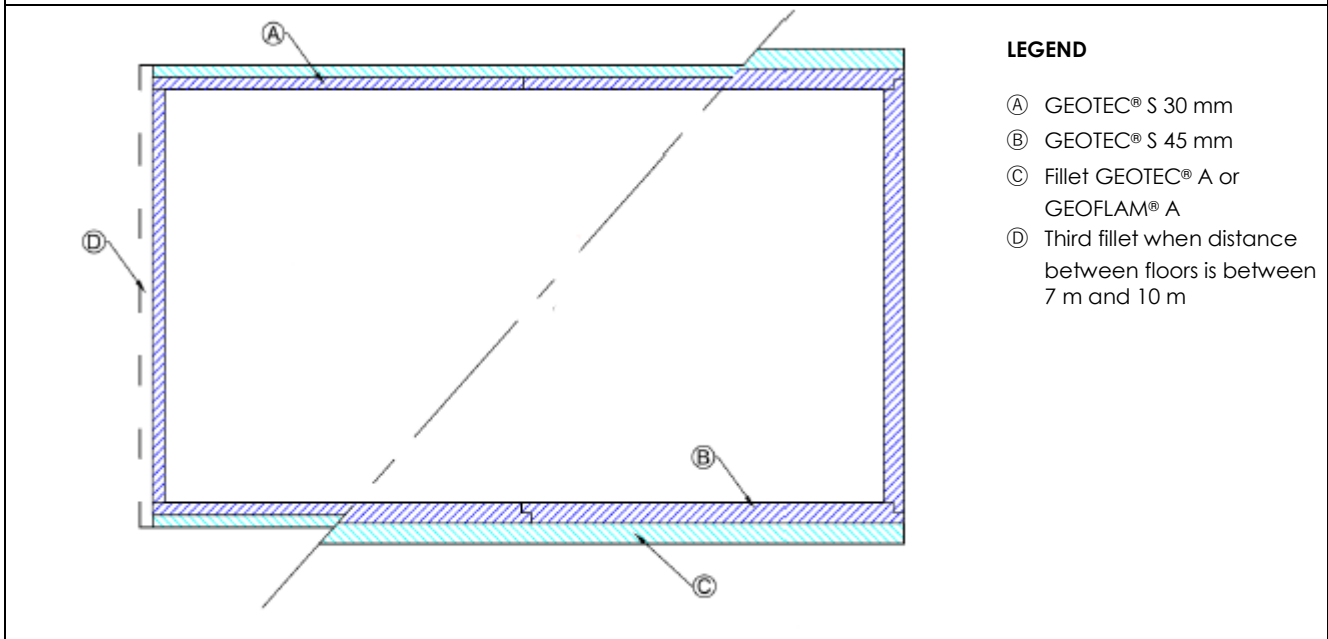

LEGEND

- Ⓐ GEOTEC® S 30 mm
- Ⓑ GEOTEC® S 45 mm
- Ⓒ Fillet GEOTEC® A or GEOFLAM® A
- Ⓓ Third fillet when distance between floors is between 7 m and 10 m

Figure 2.2.4.4.1c: Vertical duct composed of 6 or more boards, with 1 board on the short side

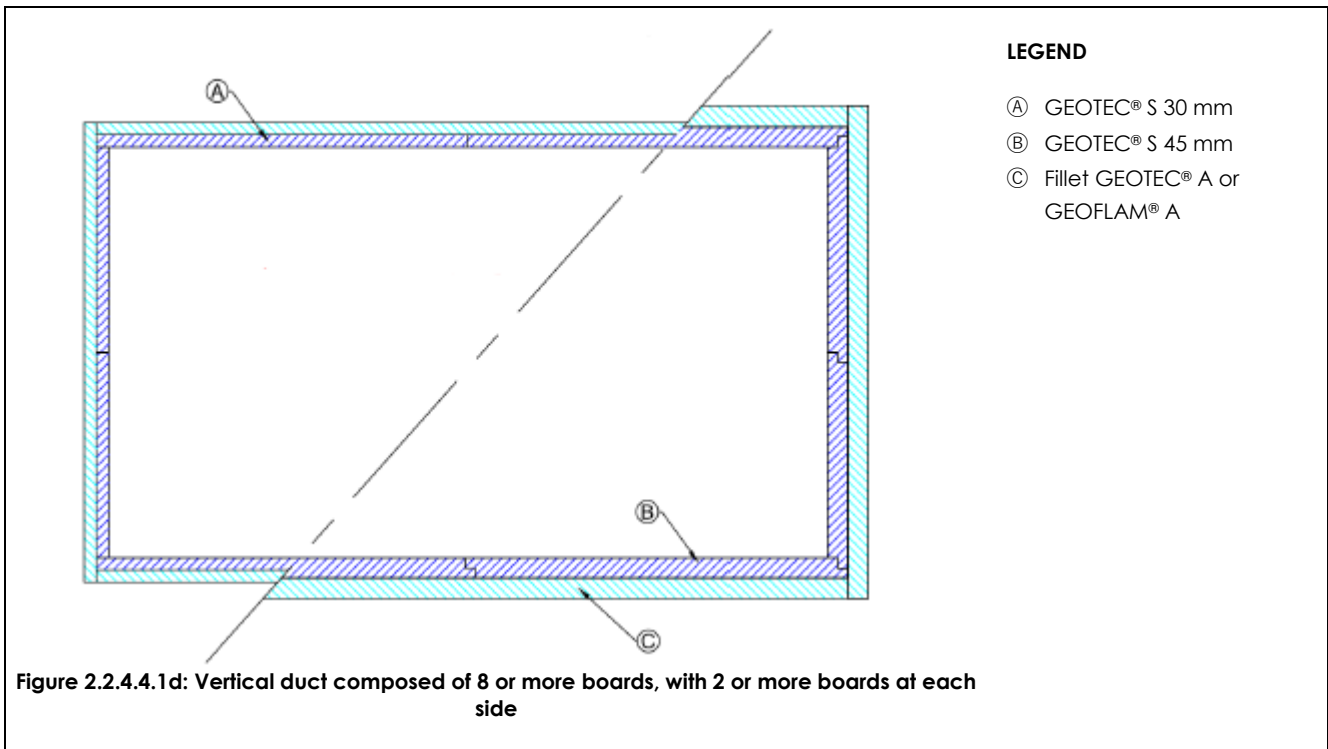

A.2.2.4.4.2. Fire protective boards

The GEOTEC® S boards are placed to form a continuous vertical duct (see figures 2.1.4.4.1.a, 2.1.4.4.1.b, 2.1.4.4.1.c and 2.1.4.4.1.d).

The boards are fixed together with GEOCOL® glue or equivalent at all edges and in the rabbets.

Caulking of vegetable fibre + plaster (such as GEOPLATRE N or similar) is applied on all joints (vertical and horizontal). The dimensions of this caulking is 50 mm by 10 mm on the horizontal or vertical joints and 20 mm by 20 mm in the corners.

Specifications for the components are given in Table A.2.2.4.4.2

Table A.2.2.4.4.2

Element	Identification	Characteristics	Mounting and fixing
Board	GEOTEC® S	Thickness: 30 or 45 mm Length: 1000 mm Width: See table 2	Installed to form a rectangular horizontal duct
Glue	GEOCOL® or equivalent	Gypsum based adhesive, in powder form	Used for fixing of the board
Caulking		Mixture of vegetal fibres and bonding plaster 50 mm by 10 mm on joints or 20 mm by 20 mm in corners	All joints are completely covered at the inside or at the outside the duct

A.2.2.4.4.3. Penetration seal

The duct penetrates 110 mm (30 mm boards) or 150 mm (45 mm boards) floors through a gap, without touching the slab. The distance between the gap and the duct is never larger than 25 mm.

The gap between the penetration wall and the duct is filled up with

- mineral wool (A1 classified according to EN 13501-1, density $\geq 26 \text{ kg/m}^3$)
- caulking made of vegetable fibres and bonding plaster (see figure 2.1.4.4.1)
- fire protective foam such as SIKA BOOM or SOUDAFOAM FR.

A.2.2.4.5 Field of direct application

The results of the fire test are directly applicable to similar constructions where one or more of the changes listed below are made and the construction continues to comply with the appropriate design code for its stiffness and stability.

- Only 4 sided ducts are covered by this classification
- Horizontal and vertical ducts according to A.2.2.4.3 and A.2.2.4.4
- The internal dimensions of the ducts are between 0 mm and 2500 mm in width by between 0 mm and 2000 mm in height.
- Vertical ducts are supported at least every 7 m or 10 m as presented in A.2.2.4.4.
- The duct may penetrate concrete walls or floors, with a thickness superior to 110 mm (30 mm boards) or 150 mm (45 mm boards) and a density superior to 550 kg/m³

A.2.2.5. Ventilation ducts and shafts composed of GEOTEC® S boards assembled by gluing and screwing

A.2.2.5.1. General

The horizontal and vertical ventilation ducts are composed of GEOTEC® S boards with a thickness of 30 mm or 45 mm. The internal dimensions of the ducts are between 0 mm by 0 mm and 2500 mm (wide) by 1500 mm (high)

A.2.2.5.2. Assembly

The ducts are composed of 1000 mm sections, build up of 4 or more 30 mm or 45 mm GEOTEC® S boards. The boards are placed with the smooth face indifferently to the inside or outside of the duct and are mounted with or without a horizontal and vertical offset of the joints from one face to the other.

The 45 mm boards have 22 mm by 23 mm rabbets at the 4 sides. The 30 mm boards have 14 mm by 16 mm rabbets only on the long sides. These rabbets may ease the assembly.

After applying GEOCOL on the rabbets and edges, the boards are connected by screws Ø 5 x 80 mm (for 30 mm boards) and Ø 5 x 90 mm (for 45 mm boards). The distance between the screws is about 120 mm.

A.2.2.5.3 Horizontal ducts

A.2.2.5.3.1. Supporting structure

The continuous self-supporting horizontal duct is composed of GEOTEC® S fire protective boards (see paragraph A.2.2.5.3.3 for details of the duct composition). The duct penetrates concrete walls with a minimum thickness of 110 mm (30 mm boards) or 150 mm (45 mm boards) (or a partition with an equivalent resistance to fire performance characteristics – see paragraph A.2.2.5.3.4. for details of penetration). The duct is supported by steel suspension system at intervals of 1000 mm (30 mm or 45 mm boards), as illustrated by figures 2.2.5.3.1.a, 2.2.5.3.1.b, 2.2.5.3.1.c, 2.2.5.3.1.d and 2.2.5.3.1.e. The joints of the bottom boards and the vertical boards shall not be staggered.

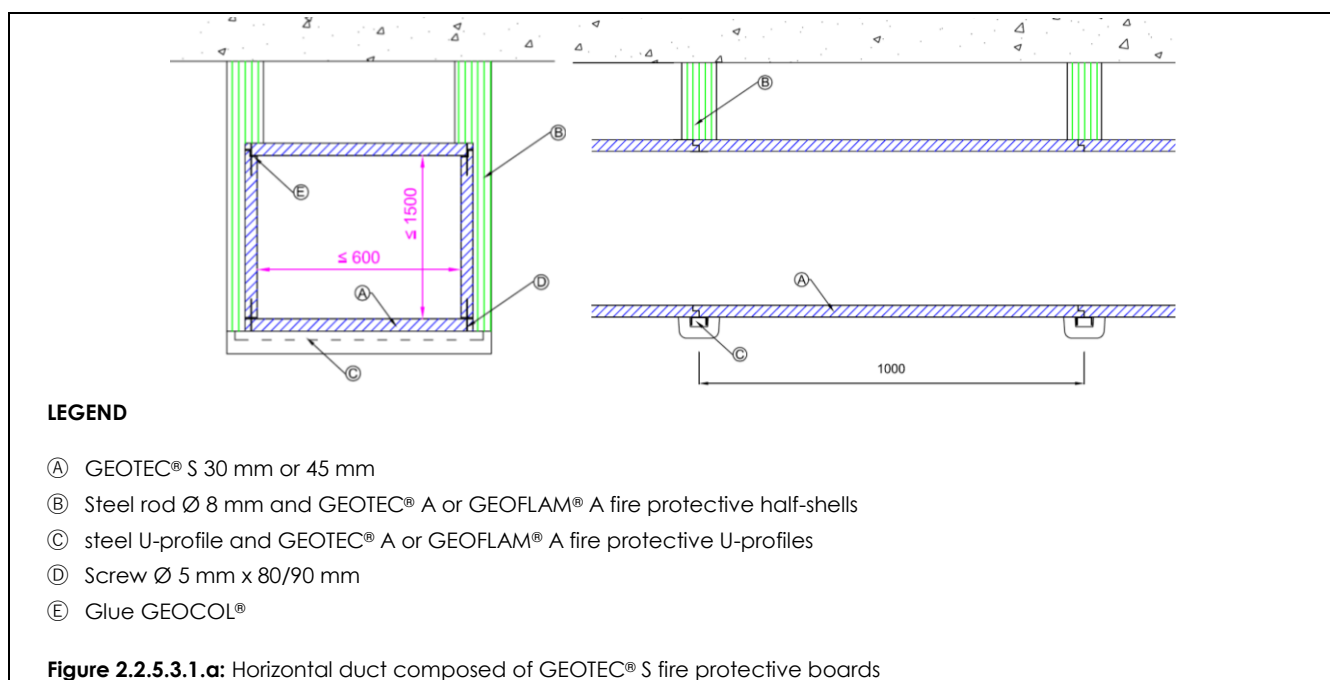

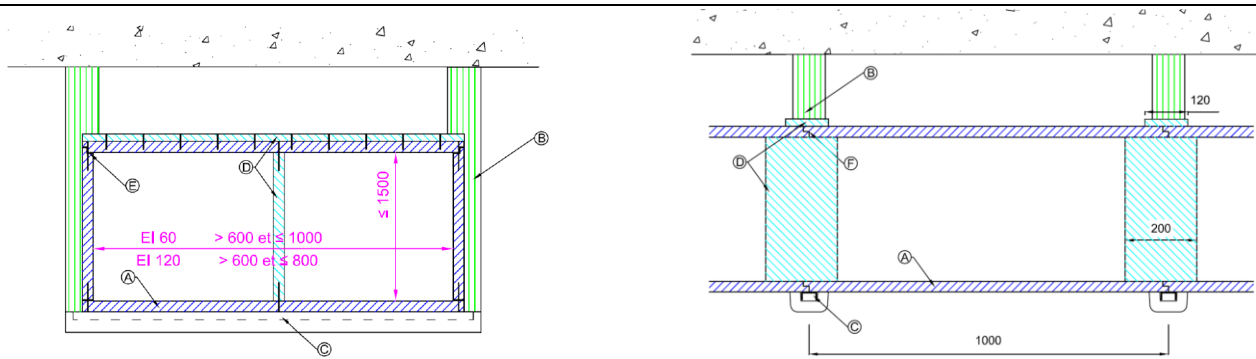

LEGEND

- (A) GEOTEC® S 30 mm or 45 mm
- (B) Steel rod Ø 8mm and GEOTEC® A or GEOFLAM® A fire protective half-shells (Rods Ø 10 mm or a third Ø 8 mm rod may apply)
- (C) steel U-profile and GEOTEC® A or GEOFLAM® A fire protective U profiles
- (D) Internal or external joint cover 120 mm by 20 mm or internal supporting structure GEOTEC® S 200 mm x 30/45 mm
- (E) Screw Ø 5 mm x 80/90 mm
- (F) Glue GEOCOL®

Figure 2.2.5.3.1.b: Horizontal duct composed of GEOTEC® S fire protective boards

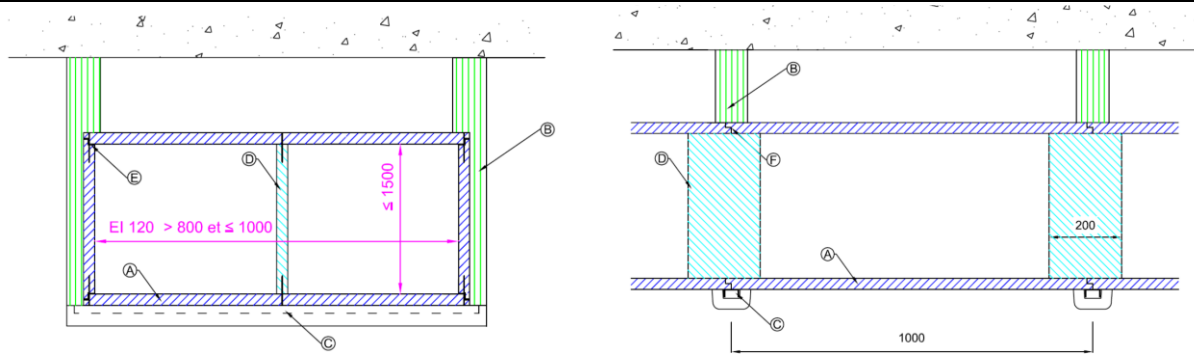

LEGEND

- (A) GEOTEC® S 45 mm
- (B) Steel rod Ø 8mm and GEOTEC® A or GEOFLAM® A fire protective half-shells (Rods Ø 10 mm or a third Ø 8 mm rod may apply)
- (C) steel U-profile and GEOTEC® A or GEOFLAM® A fire protective U profiles
- (D) internal supporting structure GEOTEC® S 200 mm x 45 mm
- (E) Screw Ø 5 mm x 90 mm
- (F) Glue GEOCOL®

Figure 2.2.5.3.1.c: Horizontal duct composed of GEOTEC® S fire protective boards

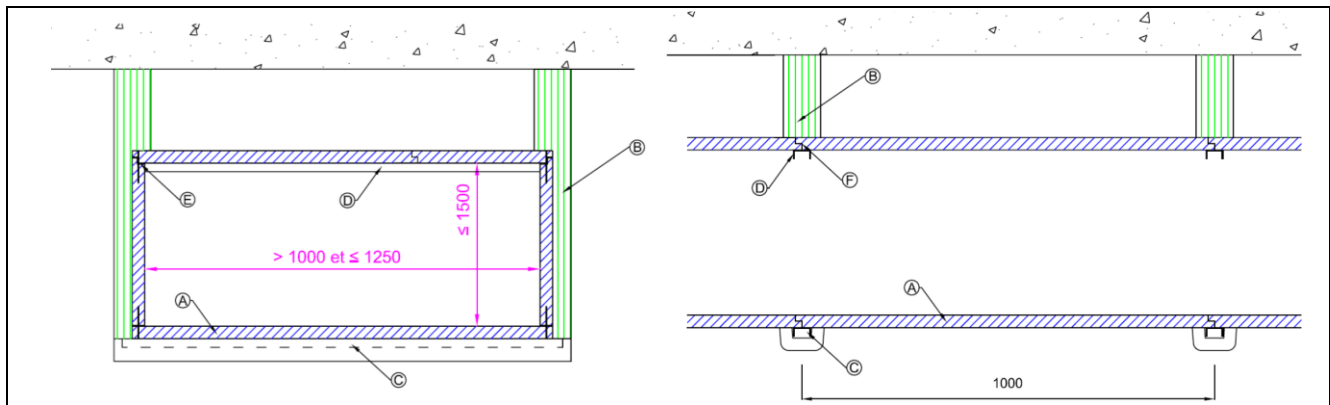

LEGEND

- (A) GEOTEC® S 30 mm/ 45 mm
- (B) Steel rod Ø 8mm and GEOTEC® A or GEOFLAM® A fire protective half-shells (Rods Ø 10 mm or a third Ø 8 mm rod may apply)
- (C) steel U-profile and GEOTEC® A or GEOFLAM® A fire protective U profiles
- (D) steel U-profile 20 x 40 (protect against fire if necessary)
- (E) Screw Ø 5 mm x 80/90 mm
- (F) Glue GEOCOL®

Figure 2.2.5.3.1.d: Horizontal duct composed of GEOTEC® S fire protective boards

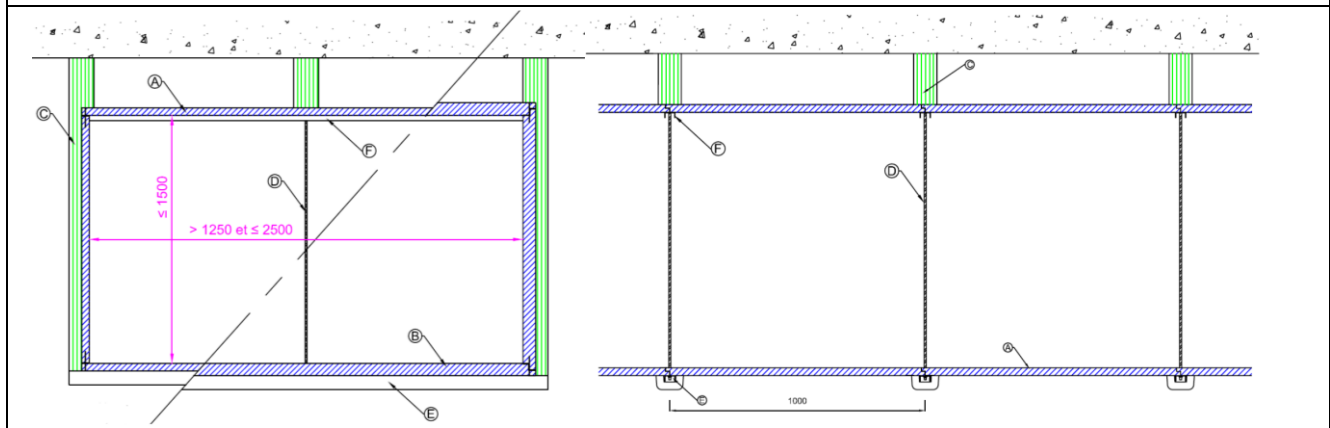

LEGEND

- (A) GEOTEC® S 30 mm
- (B) GEOTEC® S 45 mm
- (C) Steel rod Ø 8mm or Ø 10mm and GEOTEC® A or GEOFLAM® A fire protective half-shells
- (D) additional steel rod Ø 8mm (to be protected against fire when fire risk inside the duct)
- (E) steel U-profile 20 x 40 if width between 1251 mm and 2000 mm and GEOTEC® A or GEOFLAM® A fire protective U profiles
steel U-profile 41 x 41 if width greater than 2001 mm and GEOTEC® A or GEOFLAM® A fire protective U profiles
- (F) steel U-profile 20 x 40 (to be protected against fire when fire risk inside the duct)

Figure 2.2.5.3.1.e: Horizontal duct composed of GEOTEC® S fire protective boards

The suspension system, placed at 1000 mm centre distance is composed of:

- Galvanized steel rods with a diameter M8. When the internal perimeter of the duct exceeds 4500 mm rods with a diameter M10 are to be used or a third M8 rod is added in the middle. When the internal width is greater than 1251 mm a third suspension rod in the middle is required.
- Galvanized steel U-profiles – Dimensions: 20 x 40 x 20 x 2 mm or 41 X 41 X 41 x 2 mm (under the bottom board when the width of the duct is greater than 2001 mm). The length of these U-profiles is 50 mm longer than the external width of the duct. The profiles are placed under the joint between two sections.

The supporting structure outside the duct is protected against fire. The supporting structure inside the duct is protected against fire when the duct is expected to be exposed to fire from the inside.

Specifications for the components are given in Table A.2.2.5.3.1

Table A.2.2.5.3.1

Element	Identification	Characteristics	Mounting and fixing
Rods	Galvanized steel rods	M8 or M10	1000 mm centre distance (30 and 45 mm boards)
Steel U-profiles	Galvanized steel U-profiles	Dimensions : 20 x 40 x 20 x 2 mm or 41 X 41 X 41 x 2 mm Length : depending of the duct section	1000 mm centre distance (30 and 45 mm boards)

A.2.2.5.3.2. Stiffeners

Ducts with a width smaller than 600 mm, regardless the height of the duct, do not need an internal stiffener nor a joint cover.

For ducts with a width between 601 mm and 1000 mm stiffeners or joint covers are applied as given in figures 2.2.5.3.1.b and 2.2.5.3.1.c.

For ducts with a width between 1001 mm and 2500 mm, the stability of the top boards is assured by the suspension system.

A.2.2.5.3.2 Insulation

The galvanized steel rods are protected with GEOTEC® A or GEOGLAM® A fire protective shells (Ø 90 mm). The shells are composed of two half-pieces applied on the rods and fixed with GEOCOL® glue.

The galvanized steel U-profiles are protected with GEOTEC® A or GEOGLAM® A fire protective U-profiles (110/100 x 55 mm). These U-profiles are placed around the steel U-profiles and fixed with GEOCOL® glue.

When fire in the duct is expected, the steel profiles in the duct have to be protected in the same way.

Specifications for the components are given in Table A.2.2.5.3.2

Table A.2.2.5.3.2

Element	Identification	Characteristics	Mounting and fixing
Half-shells	GEOTEC® A or GEOGLAM® A	Length: 1000 mm Diameter: Ø 90 mm	Placed on steel rods and maintained with GEOCOL® glue (or equivalent)
U-profile protections	GEOTEC® A or GEOGLAM® A	Length: 1000 mm Width: 110/100 mm Thickness: 55 mm	Placed on steel U-profiles and maintained with GEOCOL® glue (or equivalent)

A.2.2.5.3.3. Fire protective boards

The GEOTEC® S boards are placed to form a continuous horizontal duct (see figures 2.2.5.3.1.a, 2.2.5.3.1.b and 2.2.5.3.1.c.).

The boards are fixed together with GEOCOL® glue or equivalent at all edges and in the rabbets and screwed, using Ø 5 x 80 mm or Ø 5 x 90 mm screws.

Specifications for the components are given in Table A.2.2.5.3.3.

Table A.2.2.5.3.3

Element	Identification	Characteristics	Mounting and fixing
Board	GEOTEC® S	Thickness: 30 or 45 mm Length: 1000 mm Width: See table 2	Installed to form a rectangular horizontal duct
Glue	GEOCOL® or equivalent	Gypsum based adhesive, in powder form	Used for fixing of the board
Screws	Wood and chipboard screw	Ø 5 x 80 mm for 30 mm boards Ø 5 x 90 mm for 45 mm boards	Centre distance 120 mm

A.2.2.5.3.4: Penetration seal

The duct penetrates 110 mm (30 mm boards) or 150 mm (45 mm boards) walls through a gap, without touching the wall. The distance between the gap and the duct is never larger than 25 mm.

The gap between the penetration wall and the duct is filled up with

- mineral wool (A1 classified according to EN 13501-1, density ≥ 26 kg/m³)
- fire protective foam such as SIKA BOOM or SOUDAFOAM FR.

The penetration may be protected with a layer of GEOCOL, applied to the penetration and the duct surface, to assure a tight seal.

A.2.2.5.4. Vertical ducts

A.2.2.5.4.1. Supporting structure

The continuous self-supporting vertical duct is composed of GEOTEC® S fire protective boards (see paragraph A.2.2.5.4.2 for details of the duct composition). The duct penetrates floors with a minimum thickness of 110 mm (30 mm boards) or 150 mm (45 mm boards) (or a floor with an equivalent resistance to fire performance characteristics – see paragraph A.2.2.5.4.3. for details of penetration). Boards are placed staggered between 200 mm and 800 mm

The vertical duct is supported by 200 mm high fillets with the same thickness as the boards to support its own weight.

For distances between the supports less than 7 m and ducts composed of 4 boards, 2 fillets are glued with GEOCOL and screwed, using Ø 5 x 50 mm or Ø 5 x 80 mm screws, on opposite sides of the duct. Screws are placed on 2 rows, at 100 mm distance from each other. When the duct is composed of more than 4 boards, a fillet is applied to each side composed of 2 or more boards.

When the distance between the supports is between 7 m and 10 m and ducts composed of 4 boards, 3 fillets are glued with GEOCOL and screwed, using Ø 5 x 50 mm for 30 mm boards or Ø 5 x 80 mm screws for 45 mm boards. When the duct is composed of more than 4 boards, a fillet is applied to each side composed of 2 or more boards, but at least 3 fillets.

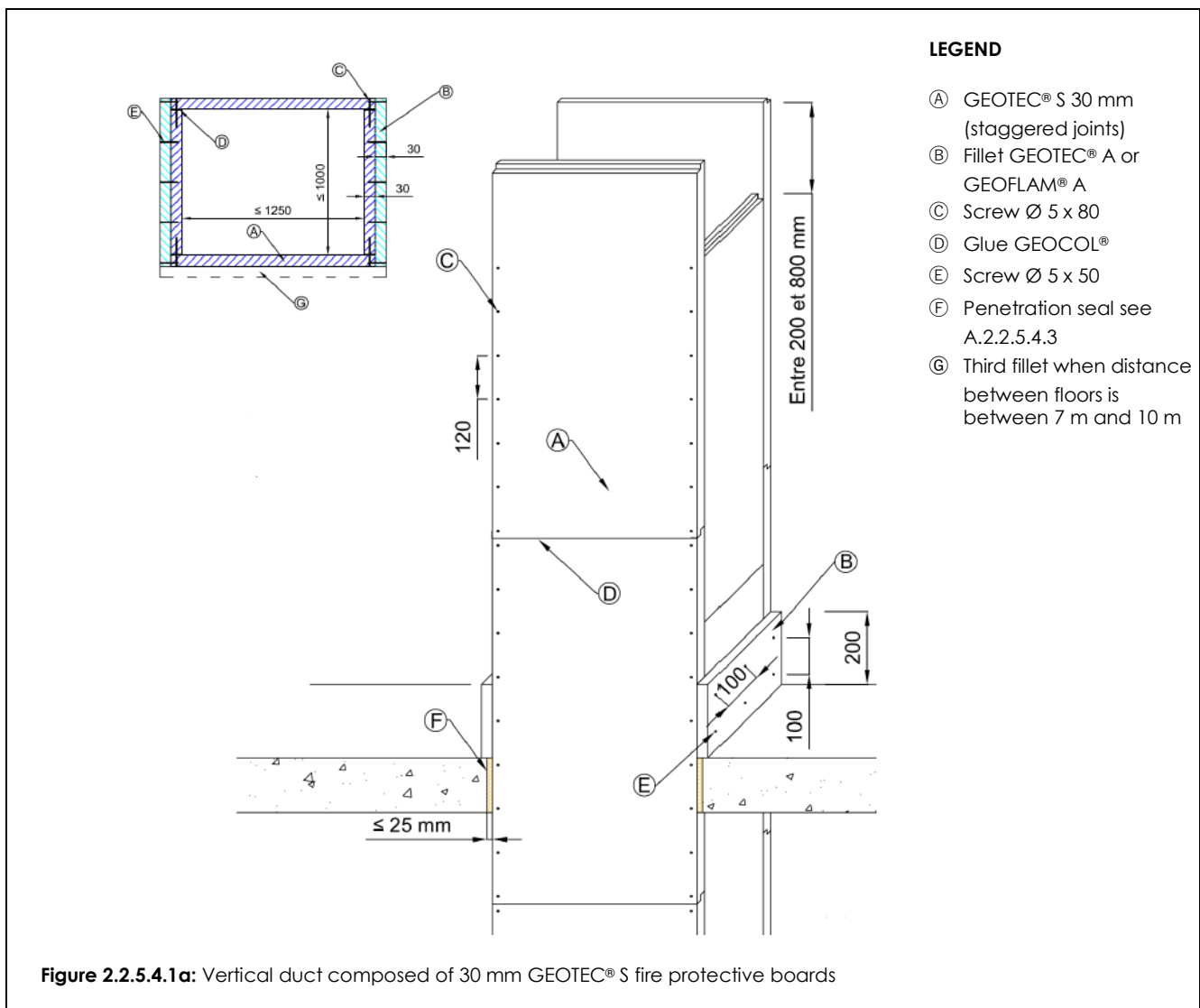

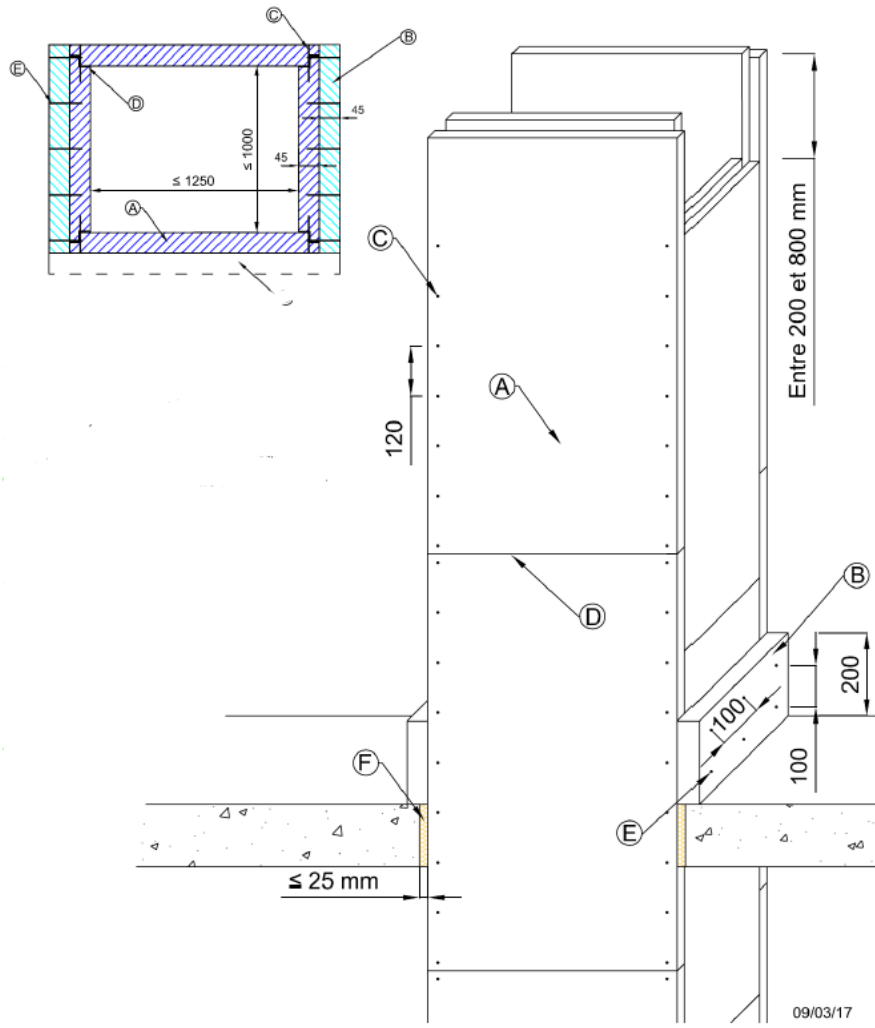

LEGEND

- Ⓐ GEOTEC® S 30 mm (staggered joints)
- Ⓑ Fillet GEOTEC® A or GEOFLAM® A
- Ⓒ Screw Ø 5 x 90
- Ⓓ Glue GEOCOL®
- Ⓔ Screw Ø 5 x 80
- Ⓕ Penetration seal see A.2.2.5.4.3
- Ⓖ Third fillet when distance between floors is between 7 m and 10 m

Figure 2.2.5.4.1b: Vertical duct composed of 45 mm GEOTEC® S fire protective boards

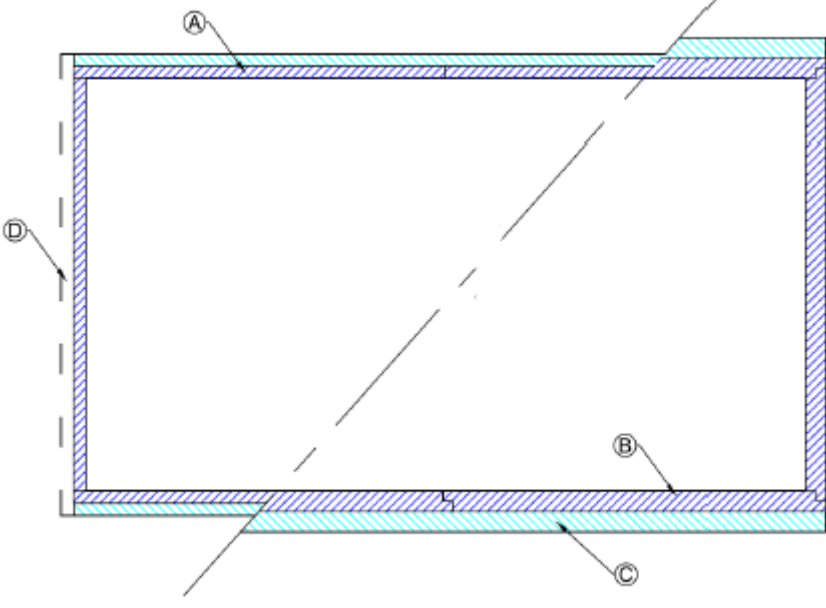

LEGEND

- Ⓐ GEOTEC® S 30 mm
- Ⓑ GEOTEC® S 45 mm
- Ⓒ Fillet GEOTEC® A or GEOFLAM® A
- Ⓓ Third fillet when distance between floors is between 7 m and 10 m

Figure 2.2.5.4.1c: Vertical duct composed of 6 or more boards, with 1 board on the short side

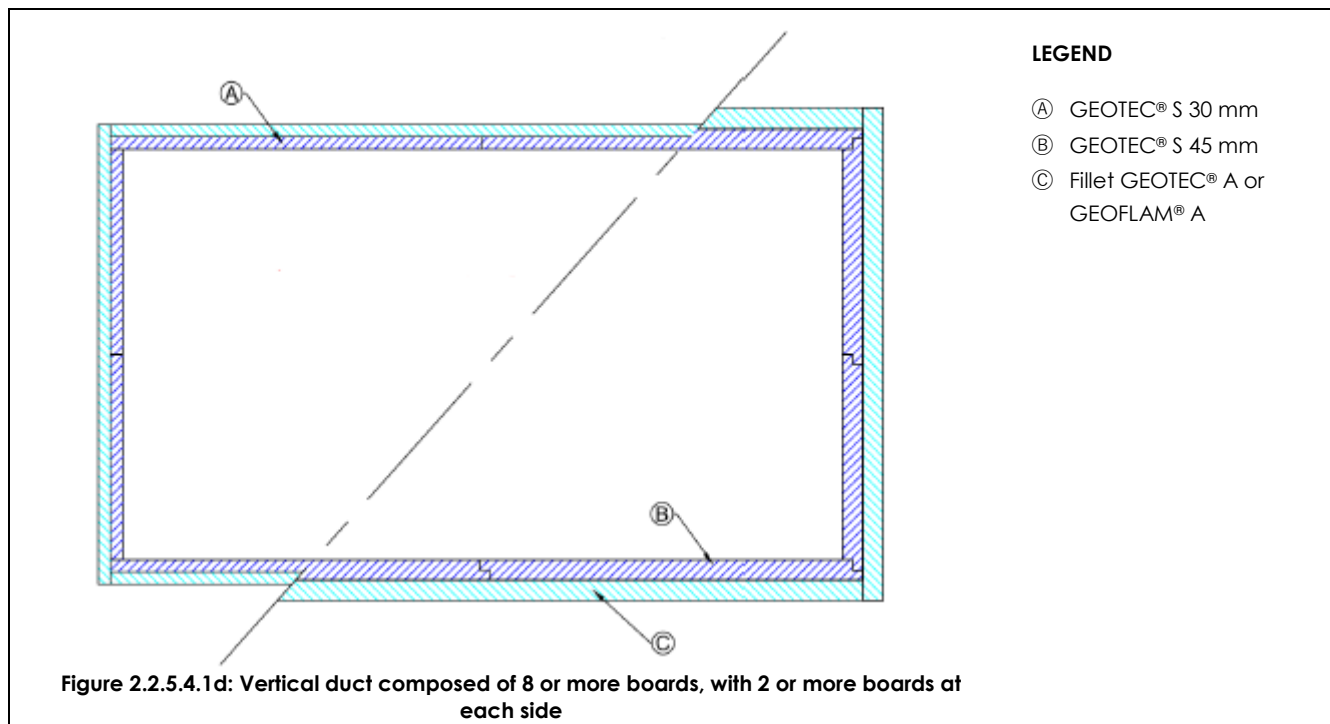

A.2.2.5.4.2. Fire protective boards

The GEOTEC® S boards are placed to form a continuous vertical duct (see figures 2.2.5.4.1.a, 2.2.5.4.1.b, 2.2.5.4.1.c and 2.2.5.4.1.d).

The boards are fixed together with GEOCOL® glue or equivalent at all edges and in the rabbets and screwed, using Ø 5 x 80 mm or Ø 5 x 90 mm screws.

Specifications for the components are given in Table A.2.2.5.4.2

Table A.2.2.5.4.2

Element	Identification	Characteristics	Mounting and fixing
Board	GEOTEC® S	Thickness: 30 or 45 mm Length: 1000 mm Width: See table 2	Installed to form a rectangular horizontal duct
Glue	GEOCOL® or equivalent	Gypsum based adhesive, in powder form	Used for fixing of the board
Screws	Wood and chipboard screw	Ø 5 x 80 mm for 30 mm boards Ø 5 x 90 mm for 45 mm boards	Centre distance 120 mm

A.2.2.5.4.3. Penetration seal

The duct penetrates 110 mm (30 mm boards) or 150 mm (45 mm boards) floors through a gap, without touching the slab. The distance between the gap and the duct is never larger than 25 mm.

The gap between the penetration wall and the duct is filled up with

- mineral wool (A1 classified according to EN 13501-1, density $\geq 26 \text{ kg/m}^3$)
- fire protective foam such as SIKA BOOM or SOUDAFOAM FR.

The penetration may be protected with a layer of GEOCOL, applied to the penetration and the duct surface, to assure a tight seal.

A.2.2.5.5 Field of direct application

The results of the fire test are directly applicable to similar constructions where one or more of the changes listed below are made and the construction continues to comply with the appropriate design code for its stiffness and stability.

- Only 4 sided ducts are covered by this classification
- Horizontal and vertical ducts according to A.2.2.5.3 and A.2.2.5.4
- The internal dimensions of the ducts are between 0 mm and 2500 mm in width by between 0 mm and 1500 mm in height.
- Vertical ducts are supported at least every 7 m or 10 m as presented in A.2.2.5.4.
- The duct may penetrate walls or floors, with a thickness superior to 110 mm (30 mm boards) or 150 mm (45 mm boards) and a density superior to 550 kg/m^3

Annex 2.3: Specification of smoke extraction ducts (intended use type 9), composed of GEOTEC® S fire protective boards,

A.2.3.1 Date of addition to this ETA

This annex was added to ETA 18/0343 on 2018-06-12. This assembly was not covered by this ETA prior to the addition of this annex.

A.2.3.2 Classification

The assembly described in this annex has been tested according to EN 1366-8 and classified (see table A.2.0.1) in accordance with EN 13501-4.

30 mm boards : **EI 60 S ve ho -1500 / +500 Pa Multi**

45 mm boards : **EI 60 S ve ho -1500 / +500 Pa Multi**

A.2.3.3 Installation requirements

Installation requirements in paragraph 2.2 of this ETA shall be taken into account.

A.2.3.4. Smoke extraction ducts and shafts composed of GEOTEC® S boards assembled by caulking

A.2.3.4.1. General

The horizontal and vertical smoke extraction ducts are composed of GEOTEC® S boards with a thickness of 30 mm or 45 mm. The internal dimensions of the ducts are between 0 mm by 0 mm and 2500 mm (wide) by 2000 mm (high)

A.2.3.4.2. Assembly

The ducts are composed of 1000 mm long sections, build-up of 4 or more 30 mm or 45 mm GEOTEC® S boards. The boards are placed with the smooth face indifferently to the inside or outside of the duct and are mounted with or without a horizontal and vertical offset of the joints from one face to the other.

The 45 mm boards have 22 mm by 23 mm rabbets at the 4 sides. The 30 mm boards have 14 mm by 16 mm rabbets only on the long sides. These rabbets may ease the assembly.

Caulking of vegetable fibre + plaster (such as GEOPLATRE N or similar) is applied on all joints (vertical and horizontal). The dimensions of this caulking is 50 mm by 10 mm on the horizontal or vertical joints and 20 mm by 20 mm in the corners.

A.2.3.4.3 Horizontal ducts

A.2.3.4.3.1. Supporting structure

The continuous self-supporting horizontal duct is composed of GEOTEC® S fire protective boards (see paragraph A.2.3.4.3.3 for details of the duct composition). The duct penetrates walls with a minimum thickness of 110 mm (30 mm boards) or 150 mm (45 mm boards) (or a partition with an equivalent resistance to fire performance characteristics – see paragraph A.2.3.4.3.4. for details of penetration). The duct is supported by steel suspension system at intervals of 1000 mm (30 mm or 45 mm boards), as illustrated by figures 2.1.4.3.1.a, 2.1.4.3.1.b and 2.1.4.3.1.c.

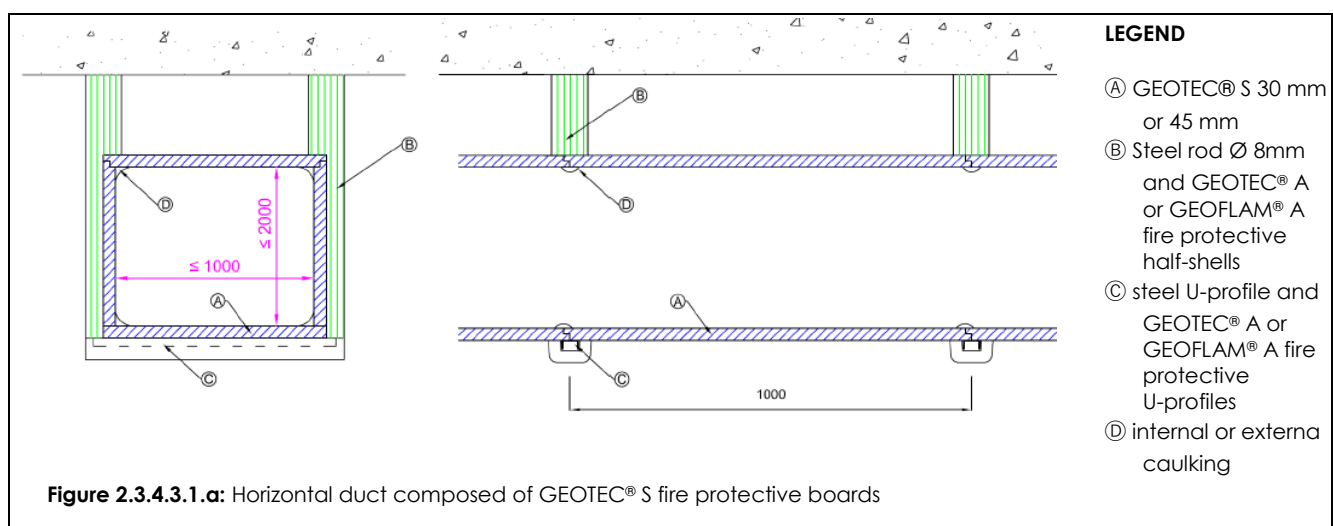

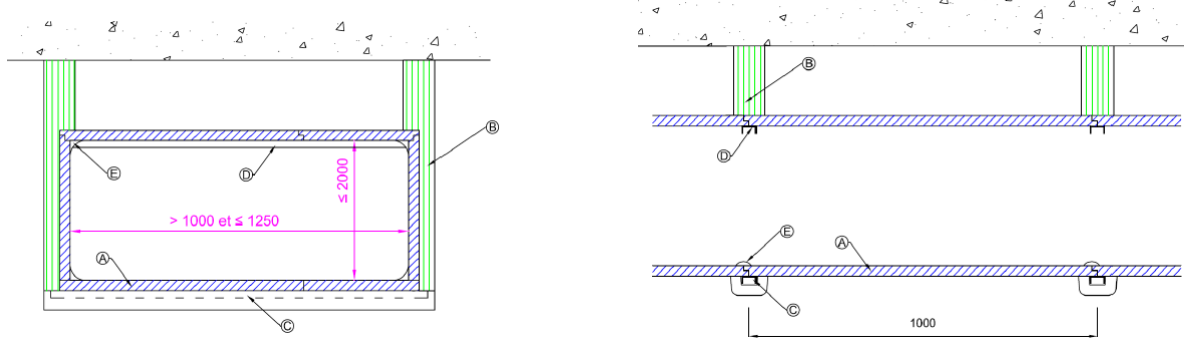

LEGEND

- (A) GEOTEC® S 30 mm or 45 mm
- (B) Steel rod Ø 8mm and GEOTEC® A or GEOFLAM® A fire protective half-shells
- (C) steel U-profile and GEOTEC® A or GEOFLAM® A fire protective U profiles
- (D) steel U-profile 20 x 40 (to be protected against fire when fire risk inside the duct)
- (E) internal or external caulking

Figure 2.3.4.3.1.b: Horizontal duct composed of GEOTEC® S fire protective boards

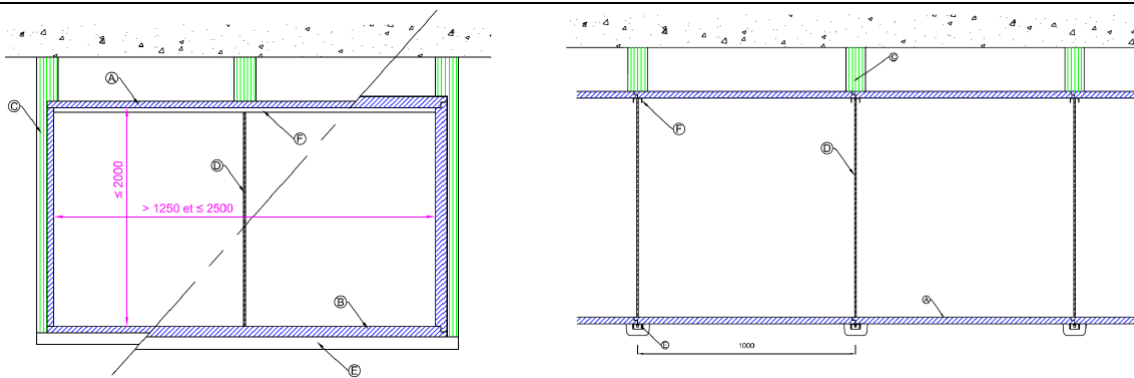

LEGEND

- (A) GEOTEC® S 30 mm
- (B) GEOTEC® S 45 mm
- (C) Steel rod Ø 8mm and GEOTEC® A or GEOFLAM® A fire protective half-shells
- (D) additional steel rod Ø 8mm (to be protected against fire when fire risk inside the duct)
- (E) steel U-profile 20 x 40 if width between 1251 mm and 2000 mm and GEOTEC® A or GEOFLAM® A fire protective U profiles
steel U-profile 41 x 41 if width greater than 2001 mm and GEOTEC® A or GEOFLAM® A fire protective U profiles
- (F) steel U-profile 20 x 40 (to be protected against fire when fire risk inside the duct)

Figure 2.3.4.3.1.c: Horizontal duct composed of GEOTEC® S fire protective boards

The suspension system, placed at 1000 mm centre distance is composed of:

- Galvanized steel rods with a diameter M8. When the internal width is greater than 1251 mm a third suspension rod in the middle is required.
- Galvanized steel U-profiles – Dimensions: 20 x 40 x 20 x 2 mm or 41 X 41 X 41 x 2 mm (when the width of the duct is greater than 2001 mm). The length of these U-profiles is 50 mm longer than the external width of the duct. The profiles are placed under the joint between two sections.

The supporting structure outside the duct is protected against fire. The supporting structure inside the duct is protected against fire when the duct is expected to be exposed to fire from the inside.

Specifications for the components are given in Table A.2.3.4.3.1

Table A.2.3.4.3.1

Element	Identification	Characteristics	Mounting and fixing
Rods	Galvanized steel rods	M8	1000 mm centre distance (30 and 45 mm boards)
Steel U-profiles	Galvanized steel U-profiles	Dimensions : 20 x 40 x 20 x 2 mm or 41 X 41 X 41 x 2 mm Length : depending of the duct section	1000 mm centre distance (30 and 45 mm boards)

A.2.3.4.3.2 Insulation

The galvanized steel rods are protected with GEOTEC® A or GEOGLAM® A fire protective shells (Ø 90 mm). The shells are composed of two half-pieces applied on the rods and fixed with GEOCOL® glue.

The galvanized steel U-profiles are protected with GEOTEC® A or GEOGLAM® A fire protective U-profiles (110/100 x 55 mm). These U-profiles are placed around the steel U-profiles and fixed with GEOCOL® glue.

When fire in the duct is expected, the steel profiles in the duct have to be protected in the same way.

Specifications for the components are given in Table A.2.3.4.3.2

Table A.2.3.4.3.2

Element	Identification	Characteristics	Mounting and fixing
Half-shells	GEOTEC® A or GEOGLAM® A	Length: 1000 mm Diameter: Ø 90 mm	Placed on steel rods and maintained with GEOCOL® glue (or equivalent)
U-profile protections	GEOTEC® A or GEOGLAM® A	Length: 1000 mm Width: 110/100 mm Thickness: 55 mm	Placed on steel U-profiles and maintained with GEOCOL® glue (or equivalent)

A.2.3.4.3.3. Fire protective boards

The GEOTEC® S boards are placed to form a continuous horizontal duct (see figures 2.1.4.3.1.a, 2.1.4.3.1.b and 2.1.4.3.1.c.).

The boards are fixed together with GEOCOL® glue or equivalent at all edges and in the rabbets.

Caulking of vegetable fibre + plaster (such as GEOPLATRE N or similar) is applied on all joints (vertical and horizontal). The dimensions of this caulking is 50 mm by 10 mm on the horizontal or vertical joints and 20 mm by 20 mm in the corners.

Specifications for the components are given in Table A.2.3.4.3.3.

Table A.2.3.4.3.3

Element	Identification	Characteristics	Mounting and fixing
Board	GEOTEC® S	Thickness: 30 or 45 mm Length: 1000 mm Width: See table 2	Installed to form a rectangular horizontal duct
Glue	GEOCOL® or equivalent	Gypsum based adhesive, in powder form	Used for fixing of the board
Caulking		Mixture of vegetal fibres and bonding plaster 50 mm by 10 mm on joints or 20 mm by 20 mm in corners	All joints are completely covered at the inside or at the outside the duct

A.2.3.4.3.4: Penetration seal

The duct penetrates 110 mm (30 mm boards) or 150 mm (45 mm boards) walls through a gap, without touching the wall. The distance between the gap and the duct is never larger than 25 mm.

The gap between the penetration wall and the duct is filled up with

- mineral wool (A1 classified according to EN 13501-1, density ≥ 26 kg/m³)
- caulking made of vegetable fibres and bonding plaster (see figure 2.1.4.1.4.2)
- fire protective foam such as SIKI BOOM or SOUDAFOAM FR.

A.2.3.4.4. Vertical ducts

A.2.3.4.4.1. Supporting structure

The continuous self-supporting vertical duct is composed of GEOTEC® S fire protective boards (see paragraph A.2.3.4.4.2 for details of the duct composition). The duct penetrates floors with a minimum thickness of 110 mm (30 mm boards) or 150 mm (45 mm boards) (or a floor with an equivalent resistance to fire performance characteristics – see paragraph A.2.3.4.4.3. for details of penetration).

The vertical duct is supported by 200 mm high fillets with the same thickness as the boards to support its own weight.

For distances between the supports less than 7 m and ducts composed of 4 boards, 2 fillets are glued on opposite sides of the duct. When the duct is composed of more than 4 boards, a fillet is applied to each side composed of 2 or more boards.

When the distance between the supports is between 7 m and 10 m and ducts composed of 4 boards, 3 fillets are glued on the sides of the duct. When the duct is composed of more than 4 boards, a fillet is applied to each side composed of 2 or more boards, but at least 3 fillets.

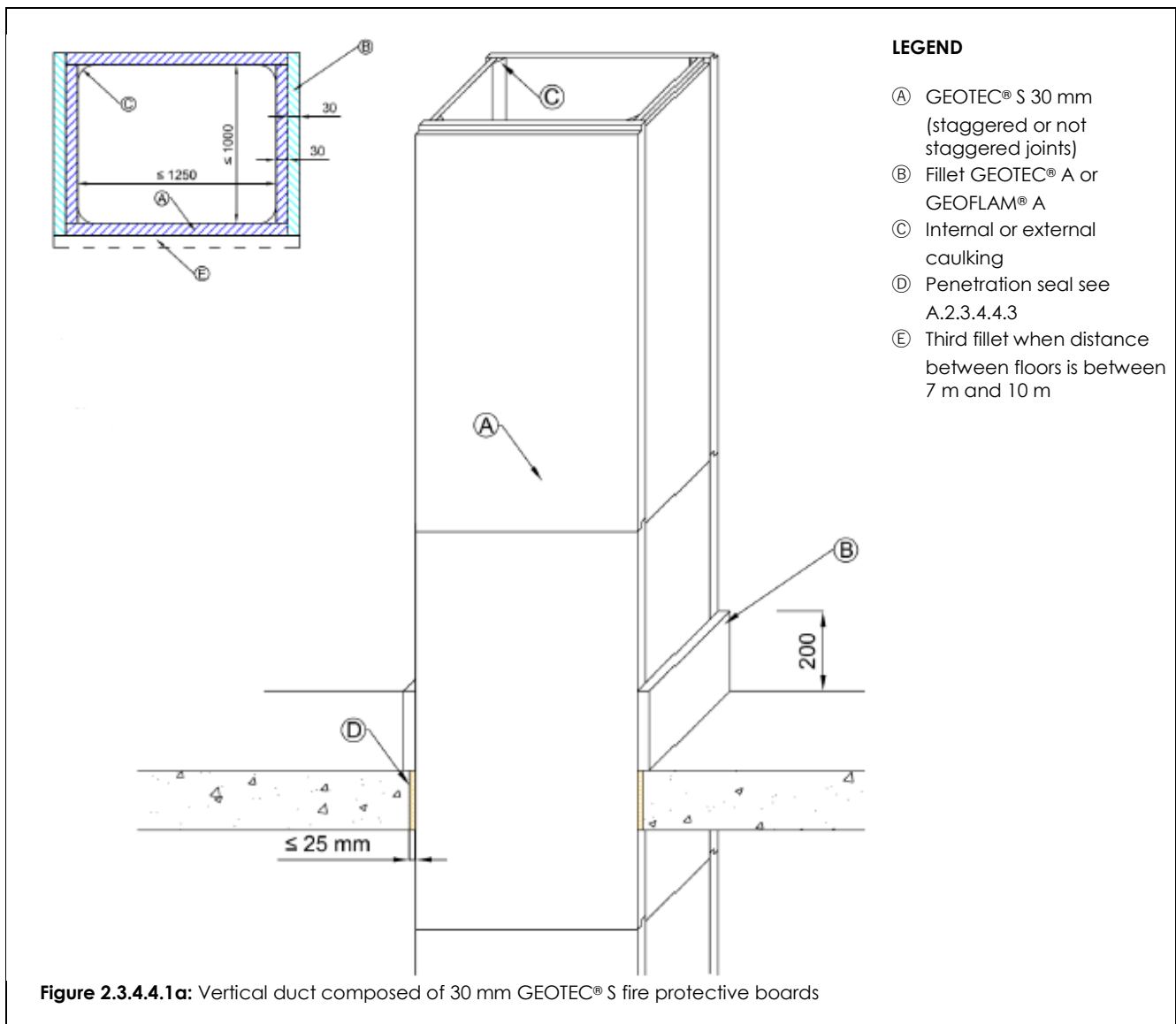

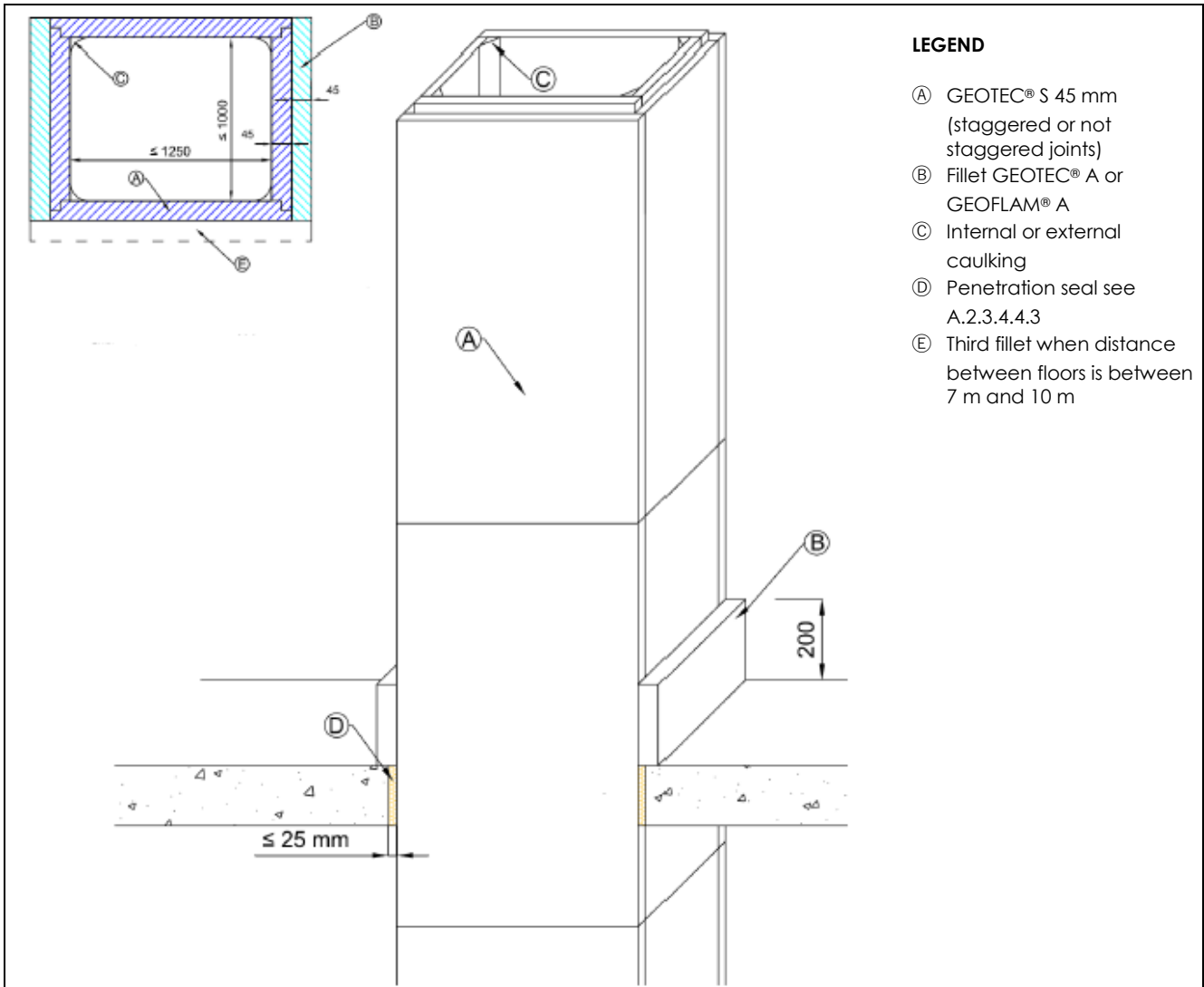

Figure 2.3.4.4.1b: Vertical duct composed of 45 mm GEOTEC® S fire protective boards

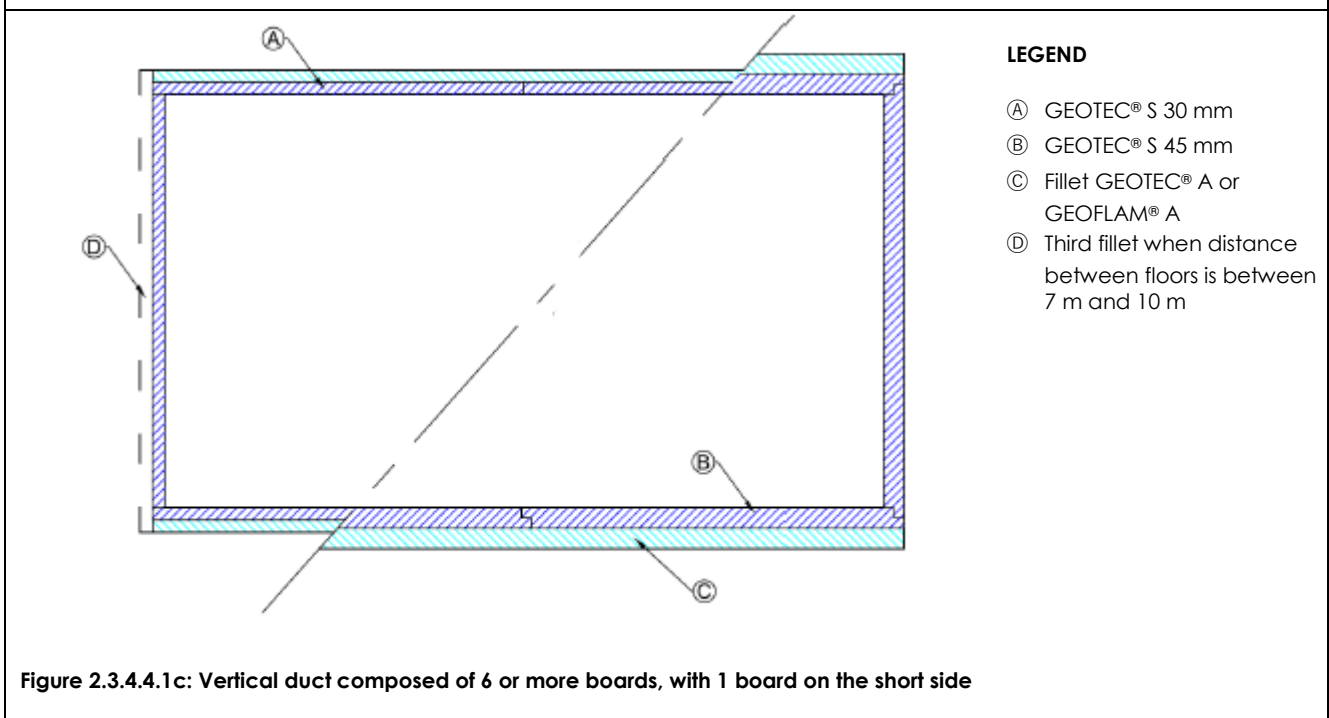
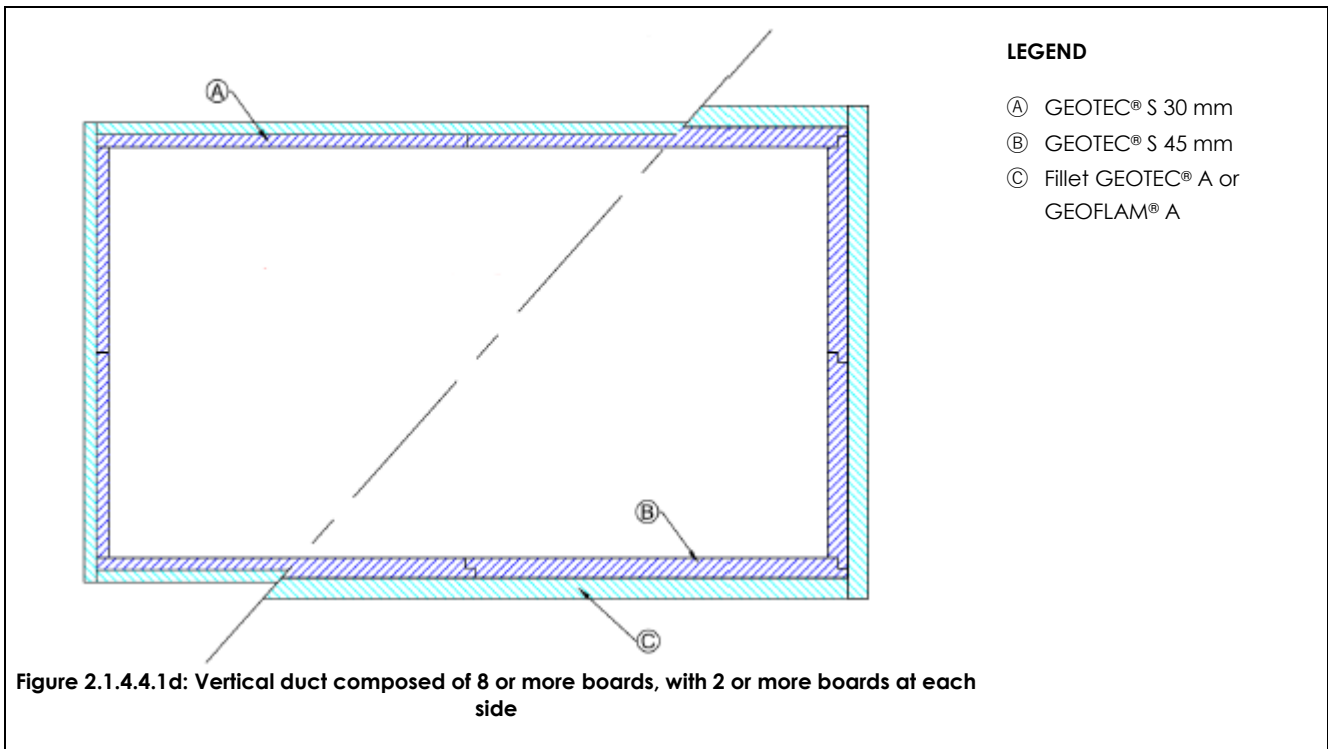

Figure 2.3.4.4.1c: Vertical duct composed of 6 or more boards, with 1 board on the short side



A.2.3.4.4.2. Fire protective boards

The GEOTEC® S boards are placed to form a continuous vertical duct (see figures 2.3.4.4.1.a, 2.3.4.4.1.b, 2.3.4.4.1.c and 2.3.4.4.1.d).

The boards are fixed together with GEOCOL® glue or equivalent at all edges and in the rabbets.

Caulking of vegetable fibre + plaster (such as GEOPLATRE N or similar) is applied on all joints (vertical and horizontal). The dimensions of this caulking is 50 mm by 10 mm on the horizontal or vertical joints and 20 mm by 20 mm in the corners.

Specifications for the components are given in Table A.2.3.4.4.2

Table A.2.3.4.4.2

Element	Identification	Characteristics	Mounting and fixing
Board	GEOTEC® S	Thickness: 30 or 45 mm Length: 1000 mm Width: See table 2	Installed to form a rectangular horizontal duct
Glue	GEOCOL® or equivalent	Gypsum based adhesive, in powder form	Used for fixing of the board
Caulking		Mixture of vegetal fibres and bonding plaster 50 mm by 10 mm on joints or 20 mm by 20 mm in corners	All joints are completely covered at the inside or at the outside the duct

A.2.3.4.4.3. Penetration seal

The duct penetrates 110 mm (30 mm boards) or 150 mm (45 mm boards) floors through a gap, without touching the slab. The distance between the gap and the duct is never larger than 25 mm.

The gap between the penetration wall and the duct is filled up with

- mineral wool (A1 classified according to EN 13501-1, density $\geq 26 \text{ kg/m}^3$)
- caulking made of vegetable fibres and bonding plaster (see figure 2.1.4.4.1)
- fire protective foam such as SIKA BOOM or SOUDAFOAM FR.

A.2.3.4.5 Field of direct application

The results of the fire test are directly applicable to similar constructions where one or more of the changes listed below are made and the construction continues to comply with the appropriate design code for its stiffness and stability.

- Only 4 sided ducts are covered by this classification
- Horizontal and vertical ducts according to A.2.3.4.3 and A.2.3.4.4
- The internal dimensions of the ducts are between 0 mm and 2500 mm in width by between 0 mm and 2000 mm in height.
- Vertical ducts are supported at least every 7 m or 10 m as presented in A.2.3.4.4.
- The duct may penetrate walls or floors, with a thickness superior to 110 mm (30 mm boards) or 150 mm (45 mm boards) and a density superior to 550 kg/m³

A.2.3.5. Smoke extraction ducts and shafts composed of GEOTEC® S boards assembled by gluing and screwing

A.2.3.5.1. General

The horizontal and vertical smoke extraction ducts are composed of GEOTEC® S boards with a thickness of 30 mm or 45 mm. The internal dimensions of the ducts are between 50 mm by 50 mm and 2500 mm (wide) by 1500 mm (high)

A.2.3.5.2. Assembly

The ducts are composed of 1000 mm sections, build-up of 4 or more 30 mm or 45 mm GEOTEC® S boards. The boards are placed with the smooth face indifferently to the inside or outside of the duct and are mounted with or without a horizontal and vertical offset of the joints from one face to the other.

The 45 mm boards have 22 mm by 23 mm rabbets at the 4 sides. The 30 mm boards have 14 mm by 16 mm rabbets only on the long sides. These rabbets may ease the assembly.

After applying GEOCOL on the rabbets and edges, the boards are connected by screws Ø 5 x 80 mm (for 30 mm boards) and Ø 5 x 90 mm (for 45 mm boards). The distance between the screws is about 120 mm.

A.2.3.5.3 Horizontal ducts

A.2.3.5.3.1. Supporting structure

The continuous self-supporting horizontal duct is composed of GEOTEC® S fire protective boards (see paragraph A.2.3.5.3.3 for details of the duct composition). The duct penetrates walls with a minimum thickness of 110 mm (30 mm boards) or 150 mm (45 mm boards) (or a partition with an equivalent resistance to fire performance characteristics – see paragraph A.2.3.5.3.4. for details of penetration). The duct is supported by steel suspension system at intervals of 1000 mm (30 mm or 45 mm boards), as illustrated by figures 2.3.5.3.1.a, 2.3.5.3.1.b, 2.3.5.3.1.c, 2.3.5.3.1.d and 2.3.5.3.1.e. The joints of the bottom boards and the vertical boards shall not be staggered.

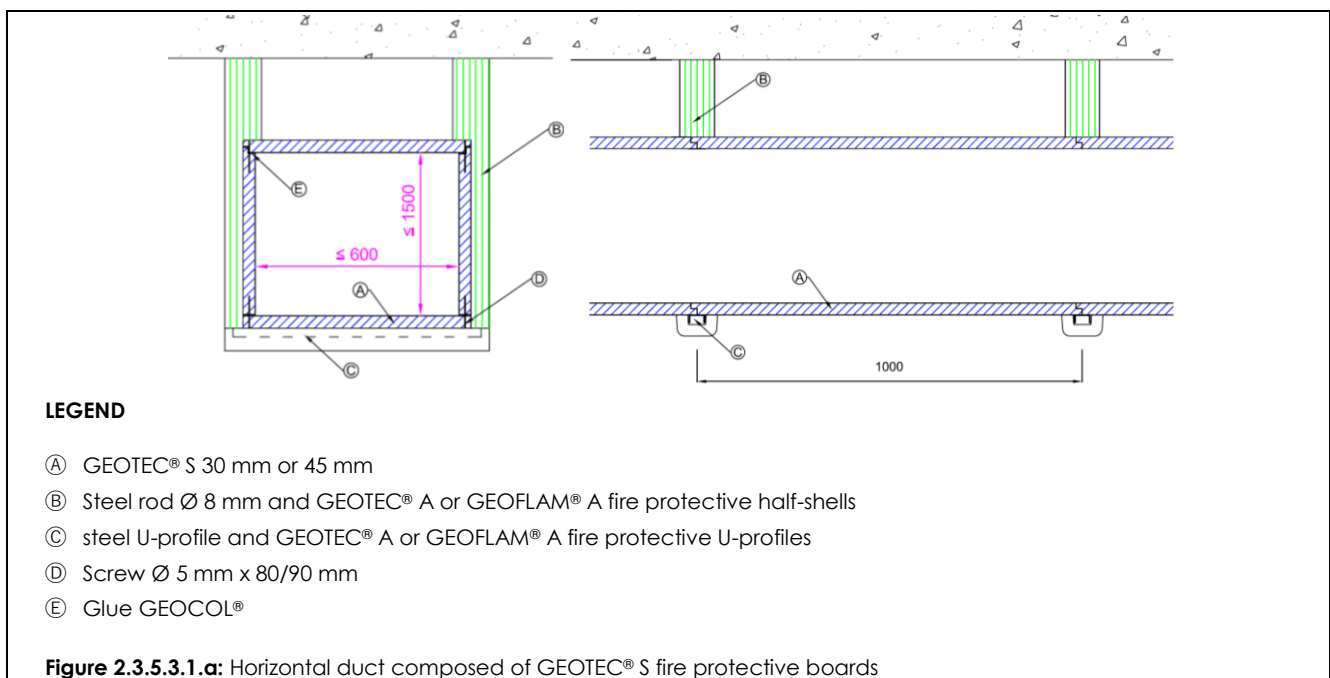

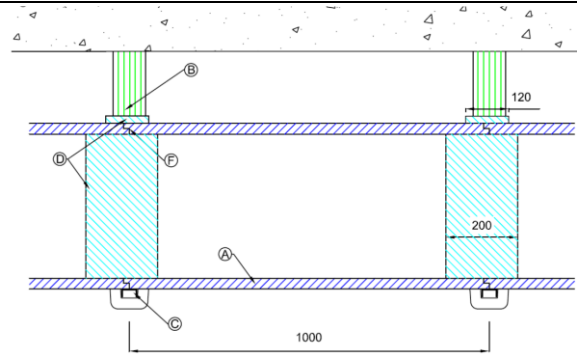
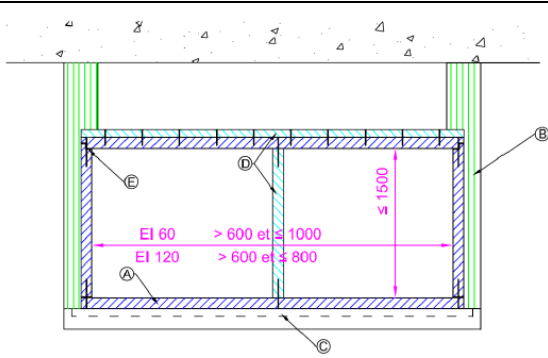

LEGEND

- (A) GEOTEC® S 30 mm or 45 mm
- (B) Steel rod Ø 8mm and GEOTEC® A or GEOFLAM® A fire protective half-shells (Rods Ø 10 mm or a third Ø 8 mm rod may apply)
- (C) steel U-profile and GEOTEC® A or GEOFLAM® A fire protective U profiles
- (D) Internal or external joint cover 120 mm by 20 mm or internal supporting structure GEOTEC® S 200 mm x 30/45 mm
- (E) Screw Ø 5 mm x 80/90 mm
- (F) Glue GEOCOL®

Figure 2.3.5.3.1.b: Horizontal duct composed of GEOTEC® S fire protective boards

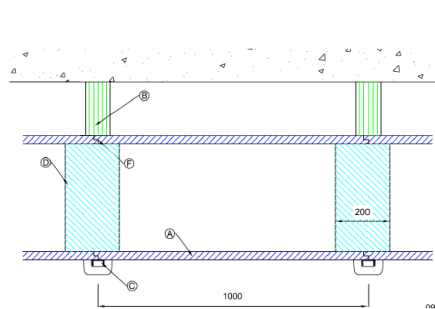
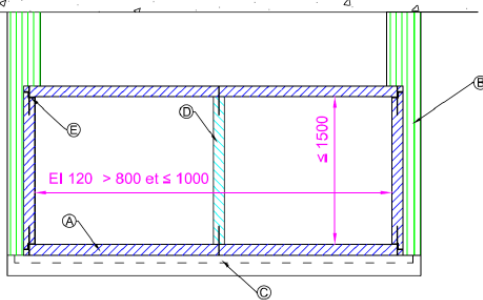

LEGEND

- (A) GEOTEC® S 30 mm or 45 mm
- (B) Steel rod Ø 8mm and GEOTEC® A or GEOFLAM® A fire protective half-shells (Rods Ø 10 mm or a third Ø 8 mm rod may apply)
- (C) steel U-profile and GEOTEC® A or GEOFLAM® A fire protective U profiles
- (D) Internal or external joint cover 120 mm by 20 mm or internal supporting structure GEOTEC® S 200 mm x 30/45 mm
- (E) Screw Ø 5 mm x 80/90 mm
- (F) Glue GEOCOL®

Figure 2.3.5.3.1.c: Horizontal duct composed of GEOTEC® S fire protective boards

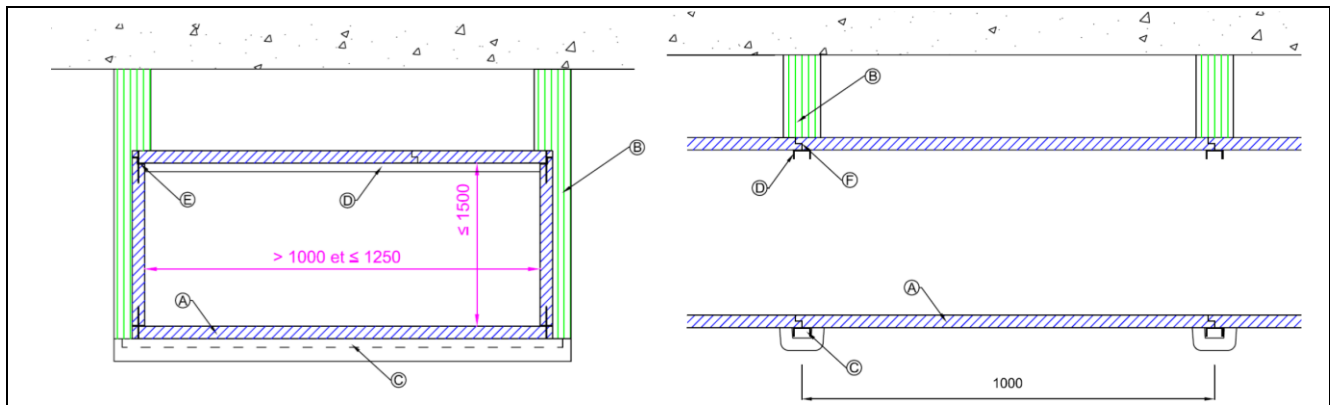

LEGEND

- (A) GEOTEC® S 45 mm
- (B) Steel rod Ø 8mm and GEOTEC® A or GEOFLAM® A fire protective half-shells (Rods Ø 10 mm or a third Ø 8 mm rod may apply)
- (C) steel U-profile and GEOTEC® A or GEOFLAM® A fire protective U profiles
- (D) steel U-profile 20 x 40 (protect against fire if necessary)
- (E) Screw Ø 5 mm x 90 mm
- (F) Glue GEOCOL®

Figure 2.3.5.3.1.d: Horizontal duct composed of GEOTEC® S fire protective boards

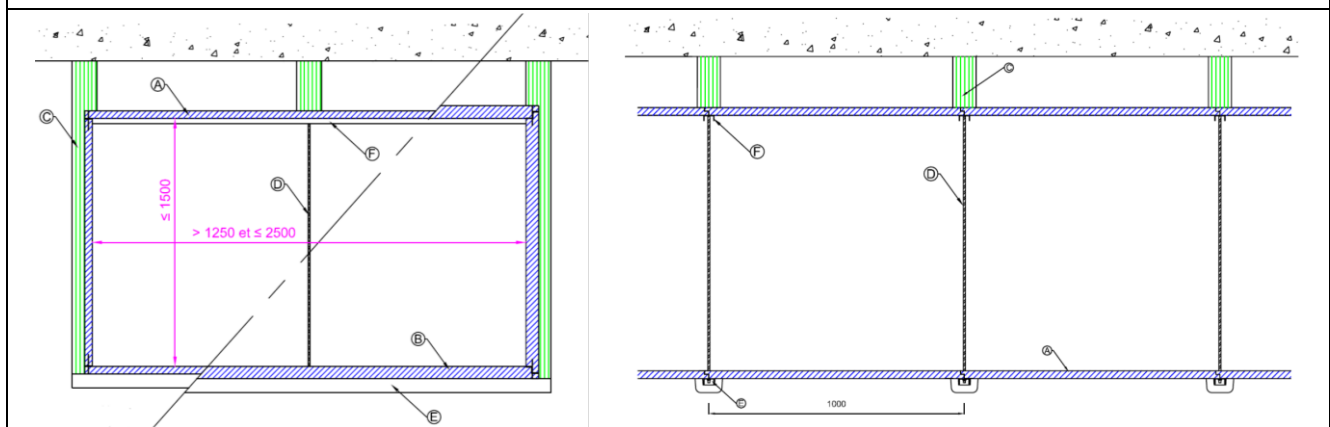

LEGEND

- (A) GEOTEC® S 30 mm
- (B) GEOTEC® S 45 mm
- (C) Steel rod Ø 8mm and GEOTEC® A or GEOFLAM® A fire protective half-shells
- (D) additional steel rod Ø 8mm (to be protected against fire when fire risk inside the duct)
- (E) steel U-profile 20 x 40 if width between 1251 mm and 2000 mm and GEOTEC® A or GEOFLAM® A fire protective U profiles
steel U-profile 41 x 41 if width greater than 2001 mm and GEOTEC® A or GEOFLAM® A fire protective U profiles
- (F) steel U-profile 20 x 40 (to be protected against fire when fire risk inside the duct)

Figure 2.3.5.3.1.e: Horizontal duct composed of GEOTEC® S fire protective boards

The suspension system, placed at 1000 mm centre distance is composed of:

- Galvanized steel rods with a diameter M8. When the internal perimeter of the duct exceeds 4500 mm rods with a diameter M10 are to be used or a third M8 rod is added in the middle. When the internal width is greater than 1251 mm a third suspension rod in the middle is required.
- Galvanized steel U-profiles – Dimensions: 20 x 40 x 20 x 2 mm or 41 X 41 X 41 x 2 mm (under the bottom board when the width of the duct is greater than 2001 mm). The length of these U-profiles is 50 mm longer than the external width of the duct. The profiles are placed under the joint between two sections.

The supporting structure outside the duct is protected against fire. The supporting structure is inside the duct is protected against fire when the duct is expected to be exposed to fire from the inside.

Specifications for the components are given in Table A.2.3.5.3.1

Table A.2.3.5.3.1

Element	Identification	Characteristics	Mounting and fixing
Rods	Galvanized steel rods	M8 or M10	1000 mm centre distance (30 and 45 mm boards)
Steel U-profiles	Galvanized steel U-profiles	Dimensions : 20 x 40 x 20 x 2 mm or 41 X 41 X 41 x 2 mm Length : depending of the duct section	1000 mm centre distance (30 and 45 mm boards)

A.2.3.5.3.2. Stiffeners

Ducts with a width smaller than 600 mm, regardless the height of the duct, do not need an internal stiffener nor a joint cover.

For ducts with a width between 601 mm and 1000 mm stiffeners or joint covers are applied as given in figures 2.3.5.3.1.b and 2.3.5.3.1.c.

For ducts with a width between 1001 mm and 2500 mm, the stability of the top boards is assured by the suspension system.

A.2.3.5.3.2 Insulation

The galvanized steel rods are protected with GEOTEC® A or GEOGLAM® A fire protective shells (Ø 90 mm). The shells are composed of two half-pieces applied on the rods and fixed with GEOCOL® glue.

The galvanized steel U-profiles are protected with GEOTEC® A or GEOGLAM® A fire protective U-profiles (110/100 x 55 mm). These U-profiles are placed around the steel U-profiles and fixed with GEOCOL® glue.

When fire in the duct is expected, the steel profiles in the duct have to be protected in the same way.

Specifications for the components are given in Table A.2.3.5.3.2

Table A.2.3.5.3.2

Element	Identification	Characteristics	Mounting and fixing
Half-shells	GEOTEC® A or GEOGLAM® A	Length: 1000 mm Diameter: Ø 90 mm	Placed on steel rods and maintained with GEOCOL® glue (or equivalent)
U-profile protections	GEOTEC® A or GEOGLAM® A	Length: 1000 mm Width: 110/100 mm Thickness: 55 mm	Placed on steel U-profiles and maintained with GEOCOL® glue (or equivalent)

A.2.3.5.3.3. Fire protective boards

The GEOTEC® S boards are placed to form a continuous horizontal duct (see figures 2.1.4.3.1.a, 2.1.4.3.1.b and 2.1.4.3.1.c.).

The boards are fixed together with GEOCOL® glue or equivalent at all edges and in the rabbets and screwed, using Ø 5 x 80 mm or Ø 5 x 90 mm screws.

Specifications for the components are given in Table A.2.3.5.3.3.

Table A.2.3.5.3.3

Element	Identification	Characteristics	Mounting and fixing
Board	GEOTEC® S	Thickness: 30 or 45 mm Length: 1000 mm 4 Width: See table 2	Installed to form a rectangular horizontal duct
Glue	GEOCOL® or equivalent	Gypsum based adhesive, in powder form	Used for fixing of the board
Screws	Wood and chipboard screw	Ø 5 x 80 mm for 30 mm boards Ø 5 x 90 mm for 45 mm boards	Centre distance 120 mm

A.2.3.5.3.4: Penetration seal

The duct penetrates 110 mm (30 mm boards) or 150 mm (45 mm boards) walls through a gap, without touching the wall. The distance between the gap and the duct is never larger than 25 mm.

The gap between the penetration wall and the duct is filled up with

- mineral wool (A1 classified according to EN 13501-1, density $\geq 26 \text{ kg/m}^3$)
- fire protective foam such as SIKA BOOM or SOUDAFOAM FR.

The penetration may be protected with a layer of GEOCOL, applied to the penetration and the duct surface, to assure a tight seal.

A.2.3.5.4. Vertical ducts

A.2.3.5.4.1. Supporting structure

The continuous self-supporting vertical duct is composed of GEOTEC® S fire protective boards (see paragraph A.2.3.5.4.2 for details of the duct composition). The duct penetrates floors with a minimum thickness of 110 mm (30 mm boards) or 150 mm (45 mm boards) (or a floor with an equivalent resistance to fire performance characteristics – see paragraph A.2.3.5.4.3. for details of penetration). Boards are placed staggered between 200 mm and 800 mm

The vertical duct is supported by 200 mm high fillets with the same thickness as the boards to support its own weight.

For distances between the supports less than 7 m and ducts composed of 4 boards, 2 fillets are glued with GEOCOL and screwed, using Ø 5 x 50 mm or Ø 5 x 80 mm screws, on opposite sides of the duct. Screws are placed on 2 rows, at 100 mm distance from each other. When the duct is composed of more than 4 boards, a fillet is applied to each side composed of 2 or more boards.

When the distance between the supports is between 7 m and 10 m and ducts composed of 4 boards, 3 fillets are glued with GEOCOL and screwed, using Ø 5 x 50 mm for 30 mm boards or Ø 5 x 80 mm screws for 45 mm boards. When the duct is composed of more than 4 boards, a fillet is applied to each side composed of 2 or more boards, but at least 3 fillets.

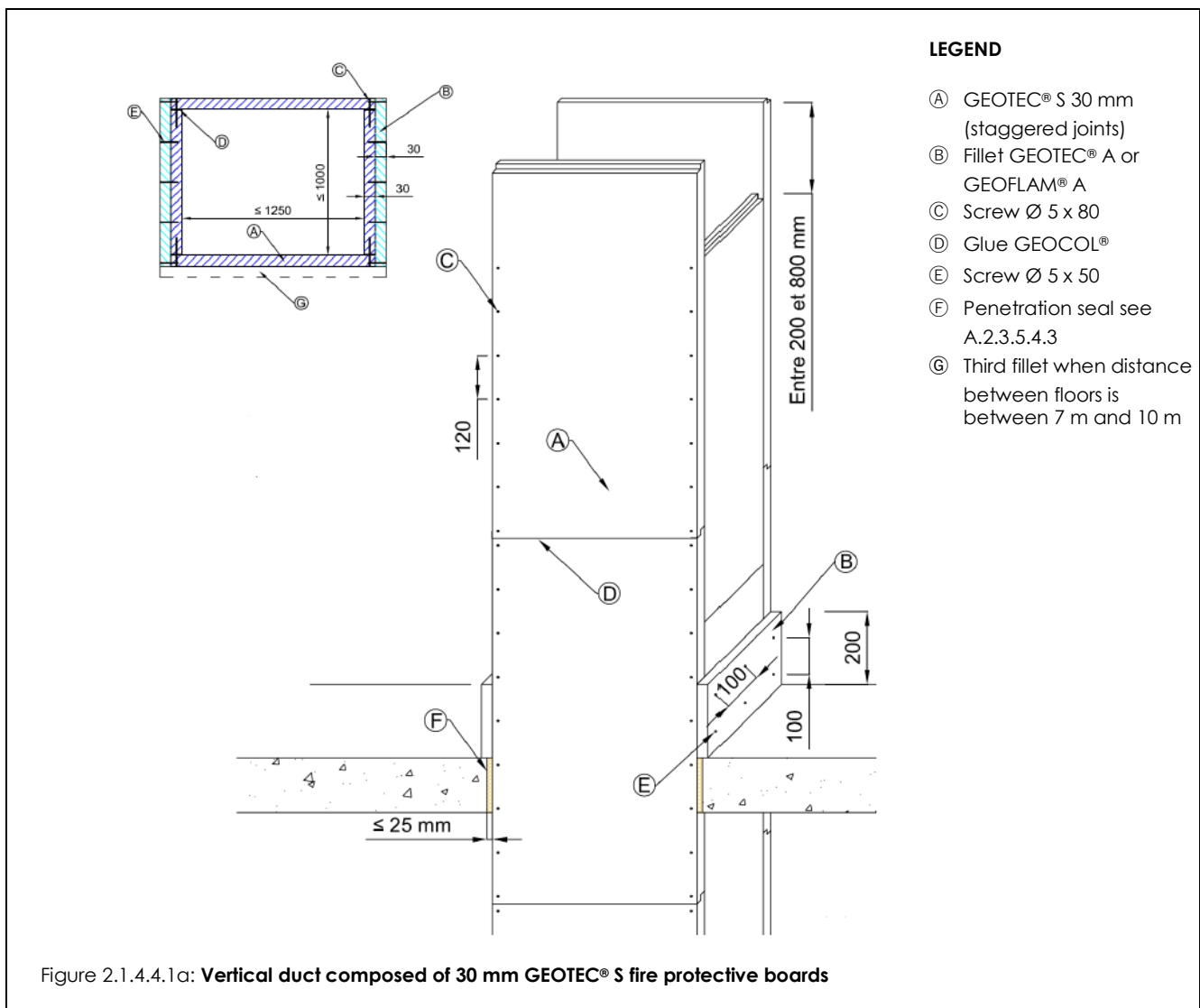

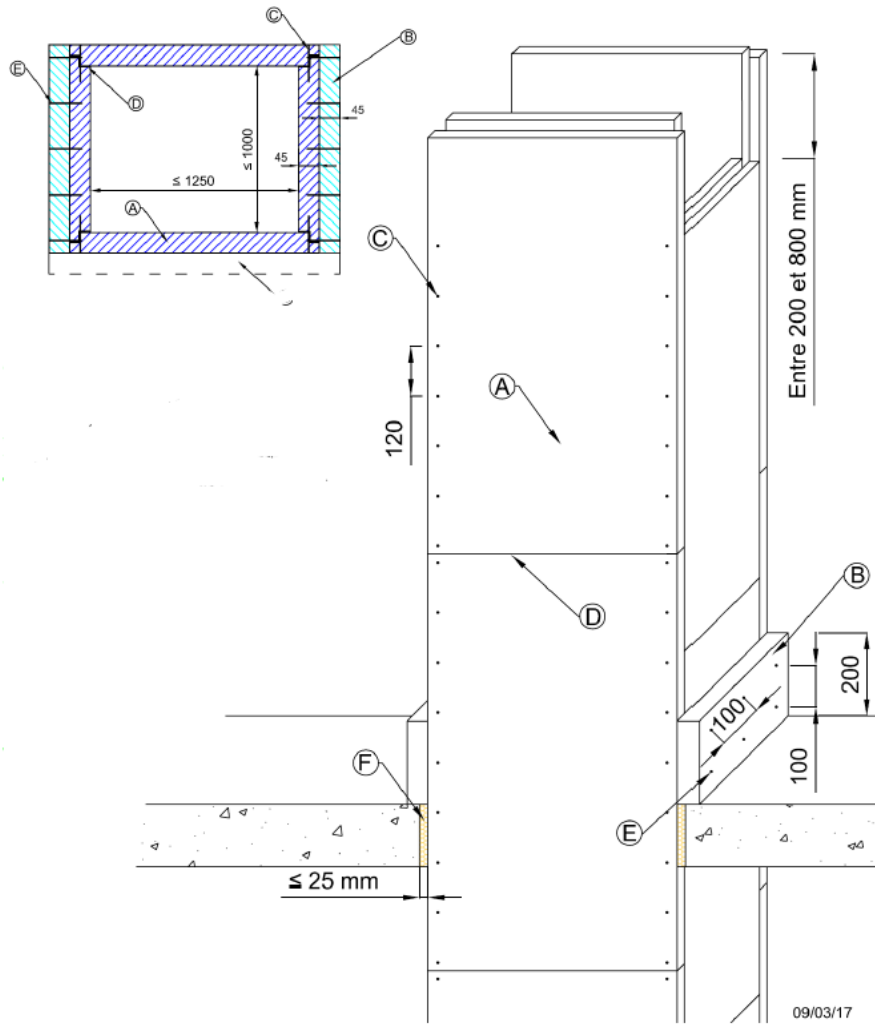

LEGEND

- Ⓐ GEOTEC® S 30 mm (staggered joints)
- Ⓑ Fillet GEOTEC® A or GEOFLAM® A
- Ⓒ Screw Ø 5 x 90
- Ⓓ Glue GEOCOL®
- Ⓔ Screw Ø 5 x 80
- Ⓕ Penetration seal see A.2.3.5.4.3
- Ⓖ Third fillet when distance between floors is between 7 m and 10 m

Figure 2.1.4.4.1b: Vertical duct composed of 45 mm GEOTEC® S fire protective boards

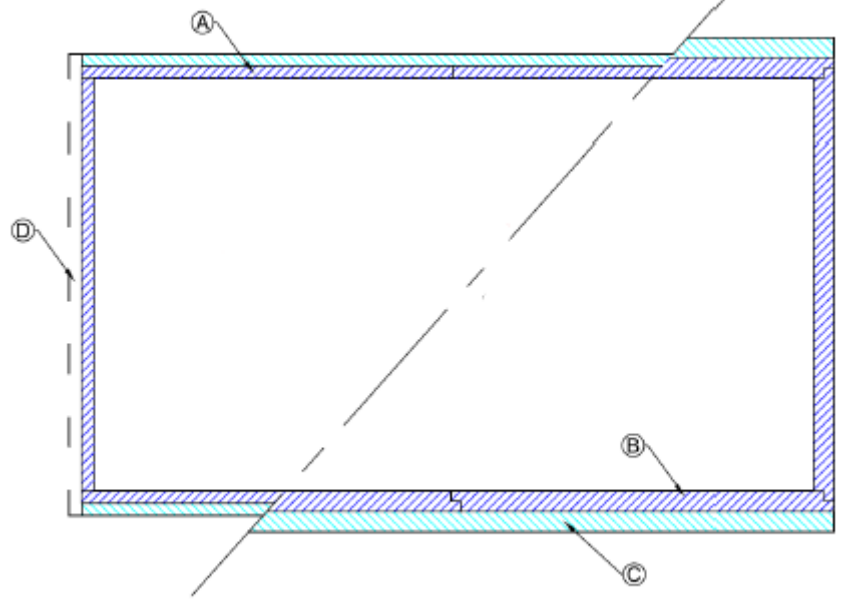

LEGEND

- Ⓐ GEOTEC® S 30 mm
- Ⓑ GEOTEC® S 45 mm
- Ⓒ Fillet GEOTEC® A or GEOFLAM® A
- Ⓓ Third fillet when distance between floors is between 7 m and 10 m

Figure 2.1.4.4.1c: Vertical duct composed of 6 or more boards, with 1 board on the short side

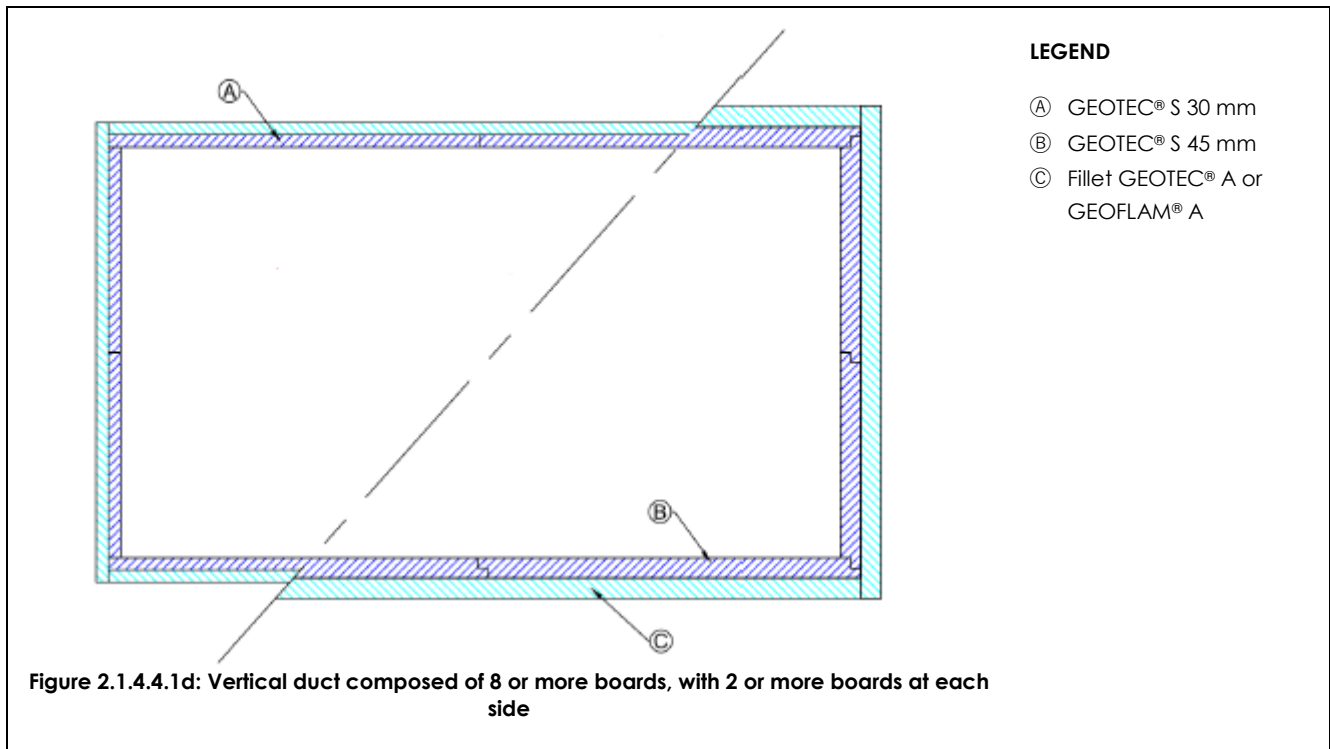

A.2.3.5.4.2. Fire protective boards

The GEOTEC® S boards are placed to form a continuous vertical duct (see figures 2.3.5.4.1.a, 2.3.5.4.1.b, 2.3.5.4.1.c and 2.3.5.4.1.d).

The boards are fixed together with GEOCOL® glue or equivalent at all edges and in the rabbets and screwed, using Ø 5 x 80 mm or Ø 5 x 90 mm screws.

Specifications for the components are given in Table A.2.3.5.4.2

Table A.2.3.5.4.2

Element	Identification	Characteristics	Mounting and fixing
Board	GEOTEC® S	Thickness: 30 or 45 mm Length: 1000 mm 4 Width: See table 2	Installed to form a rectangular horizontal duct
Glue	GEOCOL® or equivalent	Gypsum based adhesive, in powder form	Used for fixing of the board
Screws	Wood and chipboard screw	Ø 5 x 80 mm for 30 mm boards Ø 5 x 90 mm for 45 mm boards	Centre distance 120 mm

A.2.3.5.4.3. Penetration seal

The duct penetrates 110 mm (30 mm boards) or 150 mm (45 mm boards) floors through a gap, without touching the slab. The distance between the gap and the duct is never larger than 25 mm.

The gap between the penetration wall and the duct is filled up with

- mineral wool (A1 classified according to EN 13501-1, density ≥ 26 kg/m³)
- fire protective foam such as SIKA BOOM or SOUDAFOAM FR.

The penetration may be protected with a layer of GEOCOL, applied to the penetration and the duct surface, to assure a tight seal.

A.2.3.5.5 Field of direct application

The results of the fire test are directly applicable to similar constructions where one or more of the changes listed below are made and the construction continues to comply with the appropriate design code for its stiffness and stability.

- Only 4 sided ducts are covered by this classification
- Horizontal and vertical ducts according to A.2.3.5.3 an A.2.3.5.4
- The internal dimensions of the ducts are between 0 mm and 2500 mm in width by between 0 mm and 1500 mm in height.
- Vertical ducts are supported at least every 7 m or 10 m as presented in A.2.3.5.4.
- The duct may penetrate walls or floors, with a thickness superior to 110 mm (30 mm boards) or 150 mm (45 mm boards) and a density superior to 550 kg/m³